



Wall-Current-Monitor based Ghost and Satellite Bunch Detection in the CERN PS and LHC accelerators

Ralph J. Steinhausen, S. Bart-Pedersen,
J. Belleman, T. Bohl, H. Damerau

CERN Beam Instrumentation and RF Group





LHC-type Beam Production in the CERN-PS here: 50 ns beam

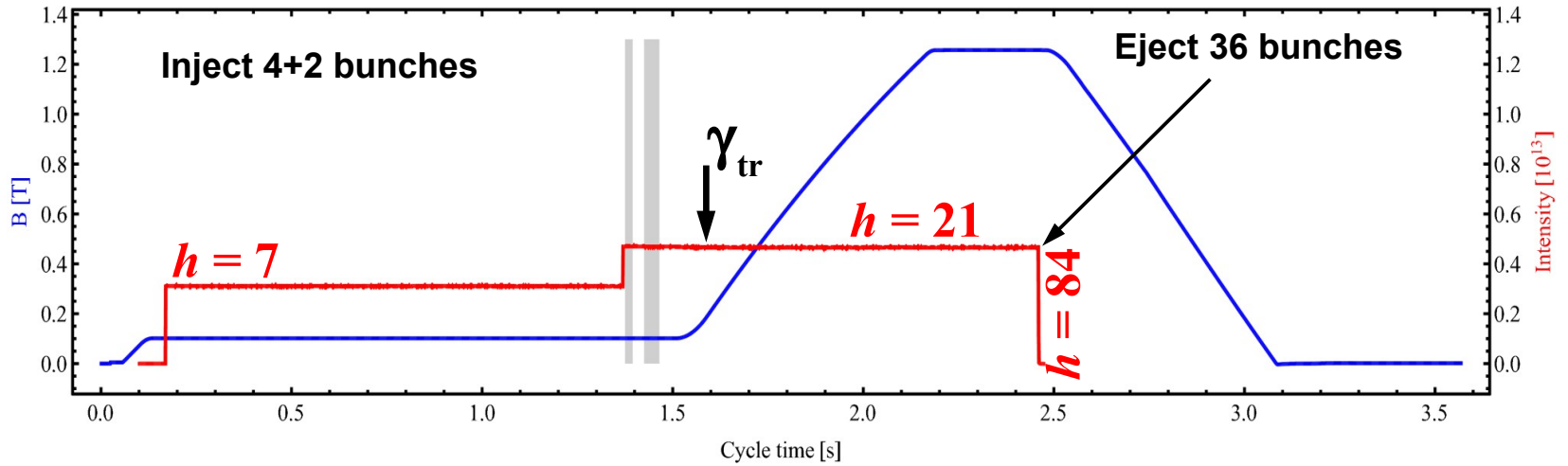

Triple splitting after 1st injection

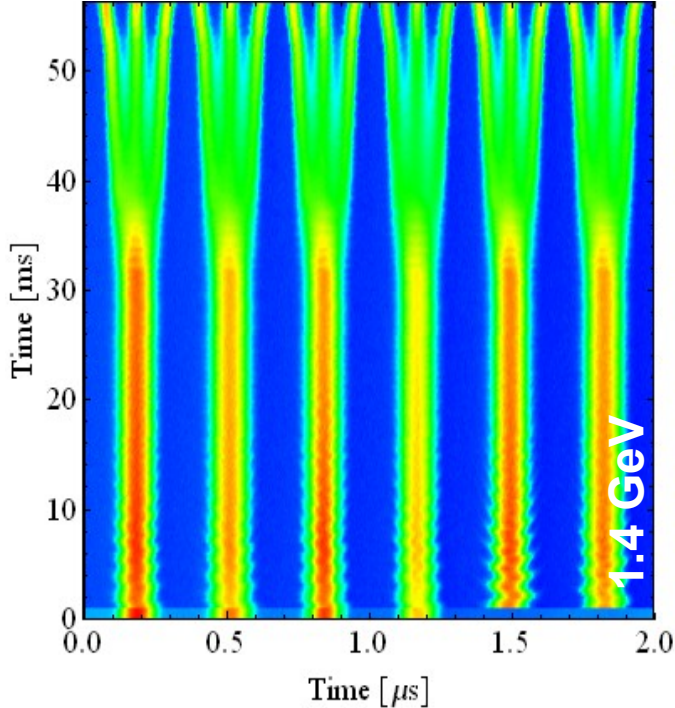

Split in two at flat top energy

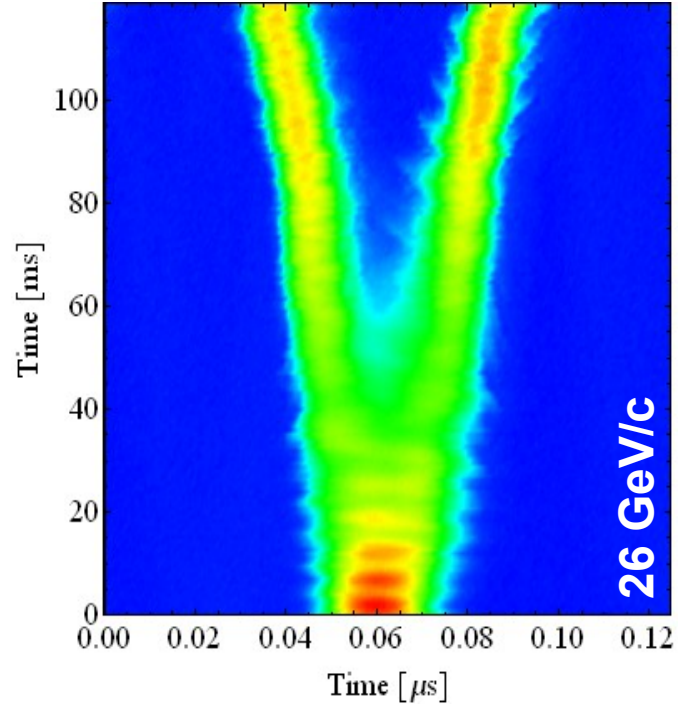

- Depending on the particle population per bucket:
 - Nominal bunch: $n_b \sim 10^9 - 1.6 \cdot 10^{11}$ p/bucket
 - 'Satellite': % -level filled buckets typ. in vicinity of nominal bunches
 - mostly PS beam production, particle transfer
 - 'Ghost': $< 10^{-4}$ w.r.t. nom. bunch filled bucket
 - capture losses/recapture beam at LHC injection

ALICE Interaction Point reconstruction:

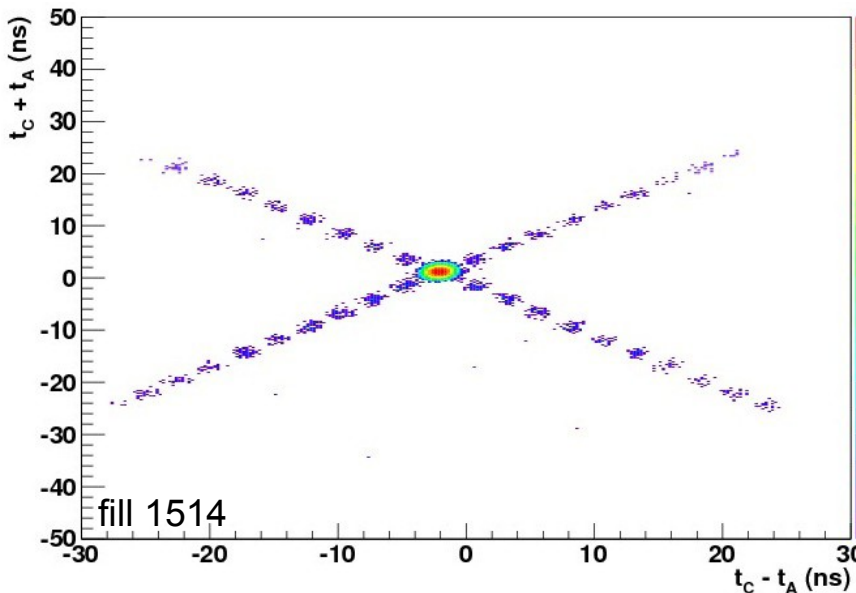

Synch-Light Single Photon Counting (APD)¹:

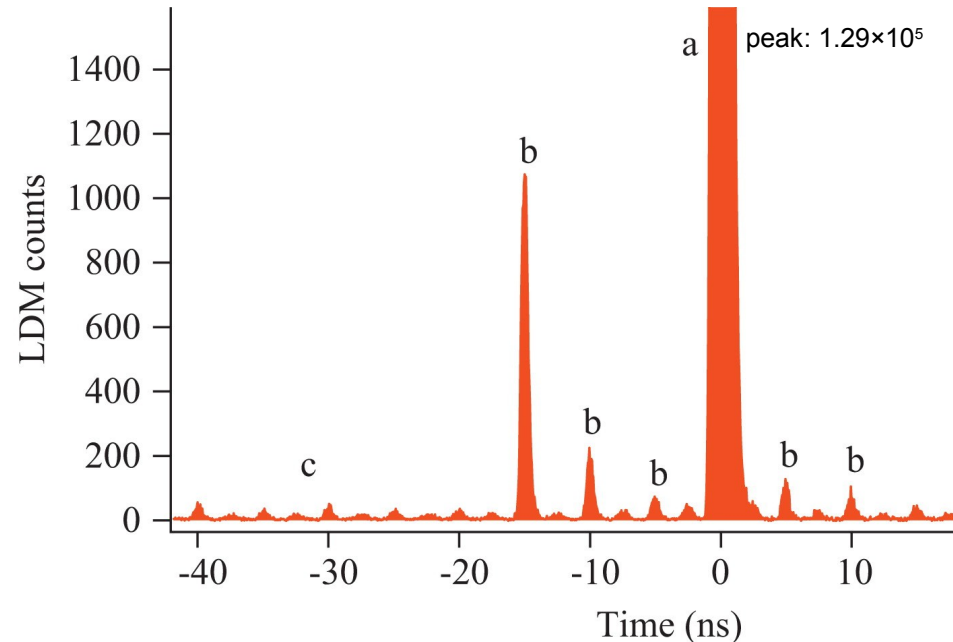

¹A. Jeff et al., "First results of the LHC longitudinal density monitor", NIMA, Vol. 659, Issue 1, 2011, pp. 549–556

- Terminology: Ghosts and Satellites

- Wall-Current Monitor Infrastructure
 - Pick-up response, cabling, star-combiner & limitations

- Intensity Measurement Resolution and Acquisition Mode

- Post-processing
 - Calibration based signal compensation with and without beam
 - Base-line restoration and noise reduction

- Some results and future plans

- WCM pickup designs based on established 78' design^{1,2,3}
- Proof-of-principle: *“What can be achieved/are the limits re-using the existing infrastructure”*
- Simplicity is key necessity to control systematics and reflections below the $<10^{-3}$ level at few-GHz:
WCM + “star combiner” → 3/8” pig-tail
 → 30 (100) m 7/8” cable
 → 40 dB attenuator → 3+ GHz fast sampling scope
- Intensity etc. measurement relies on beam-based off-/online calibration and signal post-processing

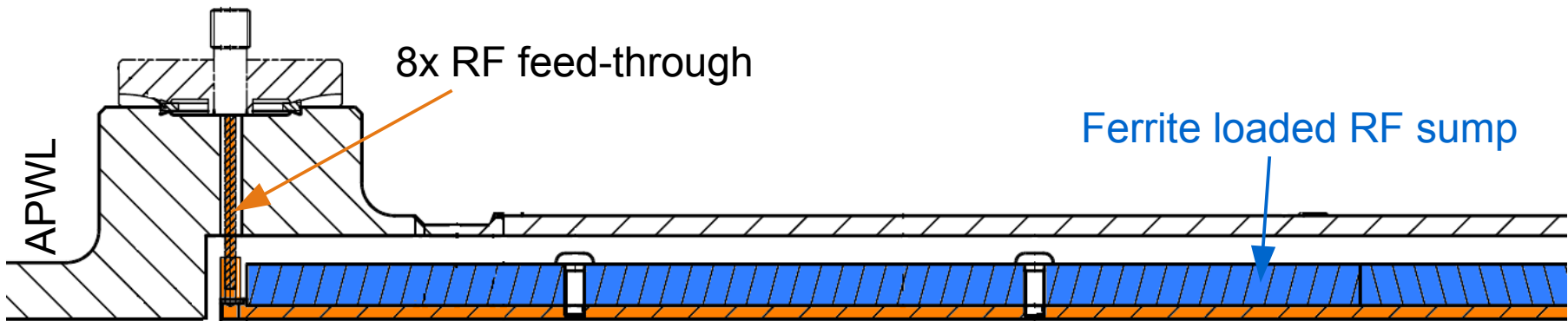
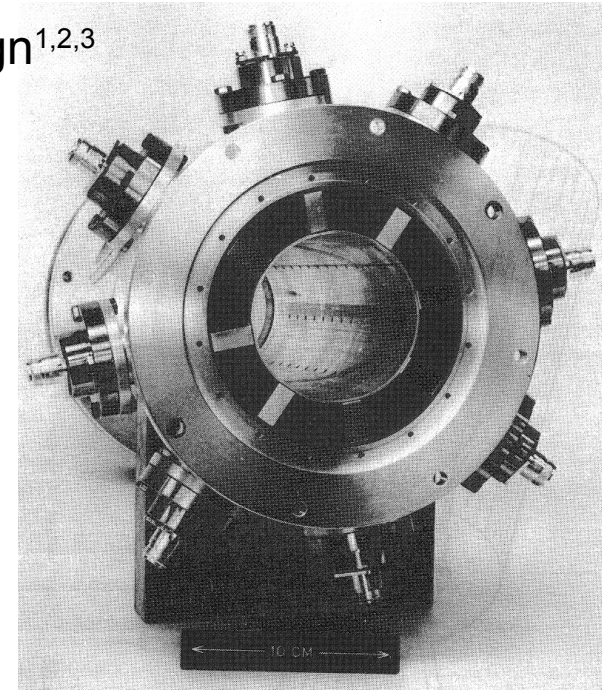

¹T. Linnecar, “The high frequency longitudinal and transverse pick-ups used in the SPS”, CERN-SPS/ARF/78-17, 1978

²Th. Bohl, “The APWL Wideband Wall Current Monitor”, CERN-BE-2009-006, 2009

³R. Cappi et al., “Single-Shot Longitudinal Shape Measurements [...]”, CERN-PS-87-31-PSR, PAC 1987, 1987

- Prior to installation

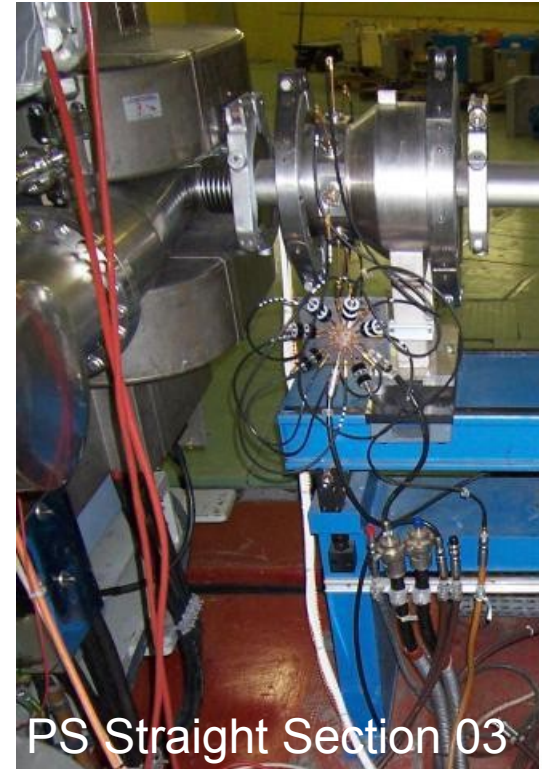
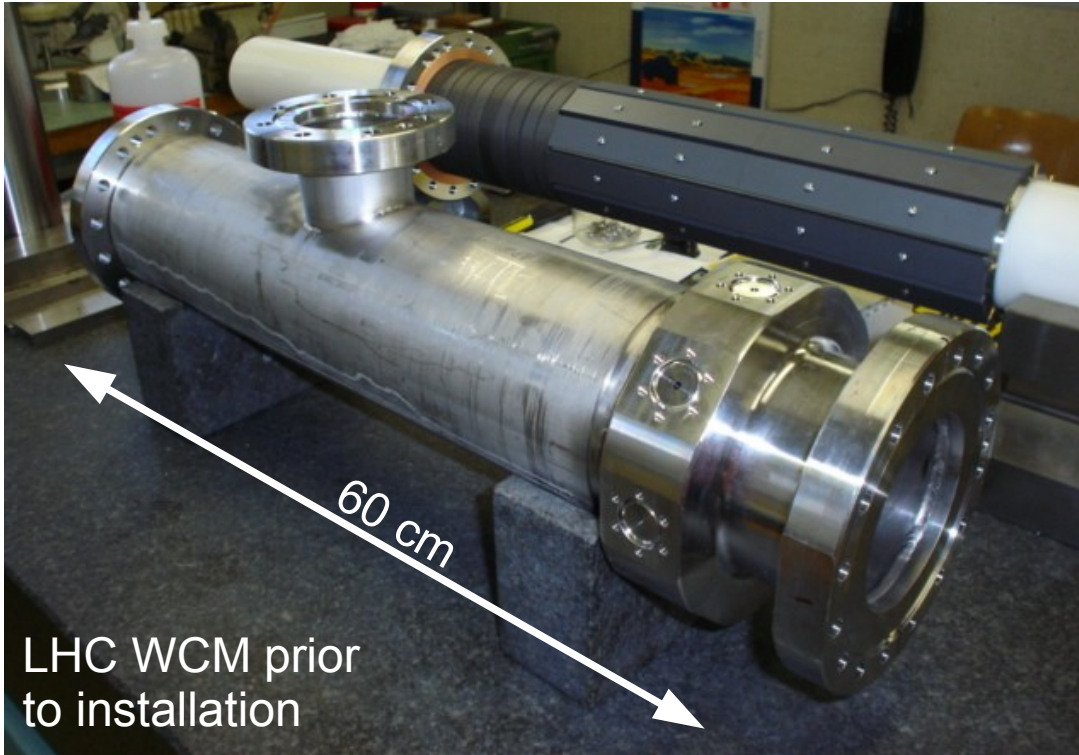

- Combiner: star-topology 8(+8) x 50 Ω -matched inputs (outputs)
- Aged/experienced PS-WCM is targeted to be upgraded for reliability and maintainability reasons

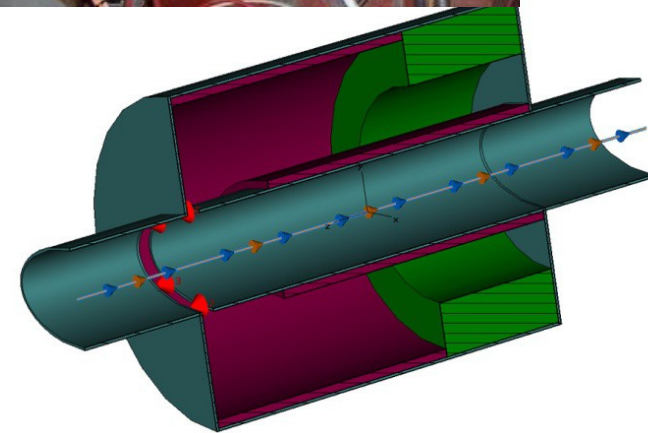

Reconstruction Requirements I/II

Typical WCM response – Low-Frequency Base-Line

- Naive approach: Fourier Integral definition for ' $\omega:=0$ ':
$$F(\omega) = \int_{-\infty}^{+\infty} f(t) e^{-i\omega t} dt$$
- However: DC information is in-accessible:

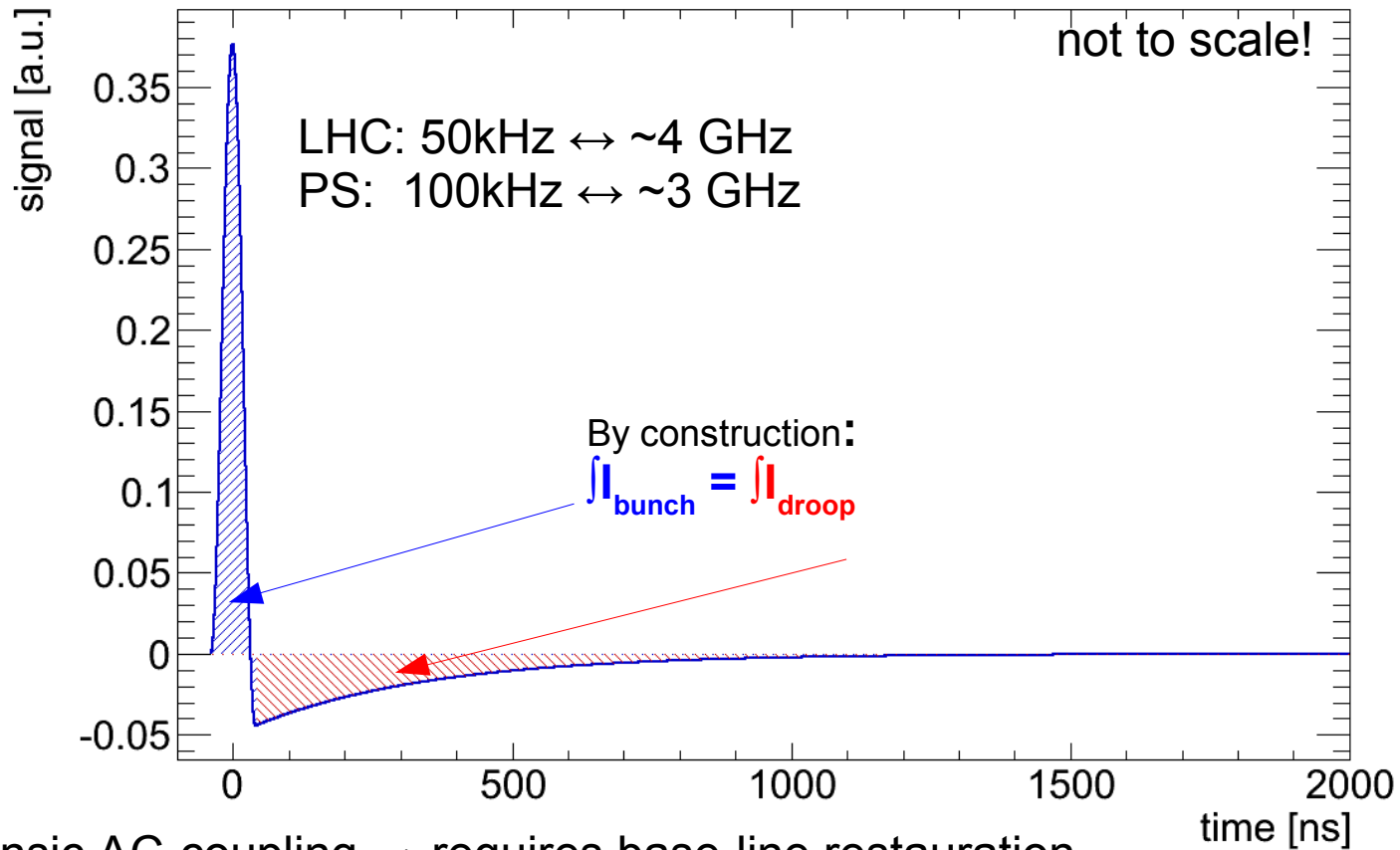

- Intrinsic AC-coupling → requires base-line restauration
 - typ. 1st-order zero-pole IIR filter works fine on %-level
 - Particularly important for filling patterns with many bunches (LHC: <2808)
 - observed sub-%-level drifts related bunch-filling pattern, bunch charge,...

- Need high pick-up and cable bandwidth to distinguish between large bunches and tiny satellites/ghosts in the vicinity:

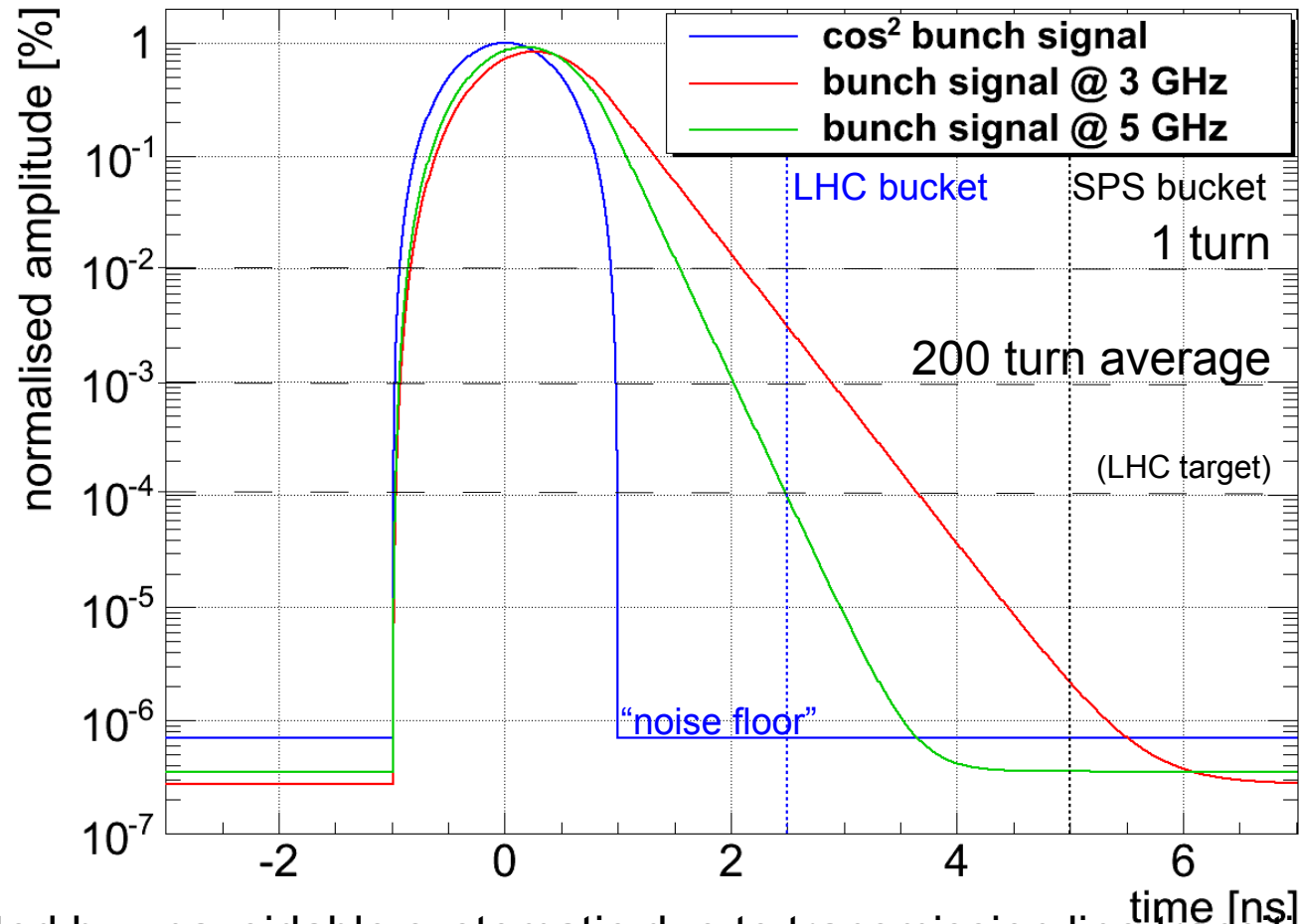

- ... limited by unavoidable systematic due to transmission line transitions, reflections, etc. (N.B. difficult to control better than 10^{-3} on > 2 m distances)

- “Re-discovered” expected position dependence while doing a ± 5 mm orbit bump around LHC-Pt4 (RF, BI insertion):

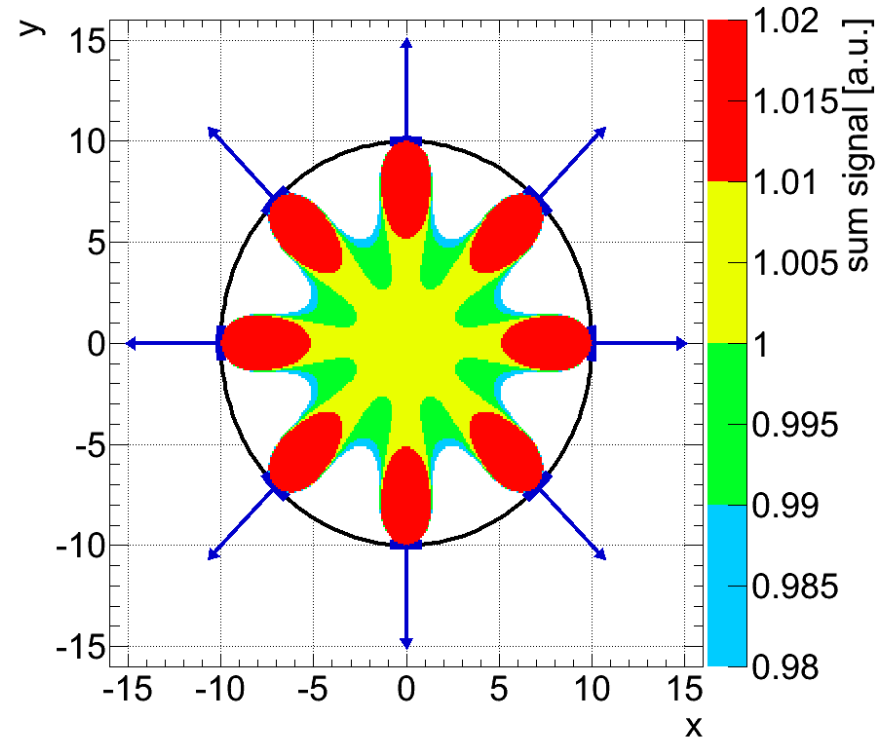
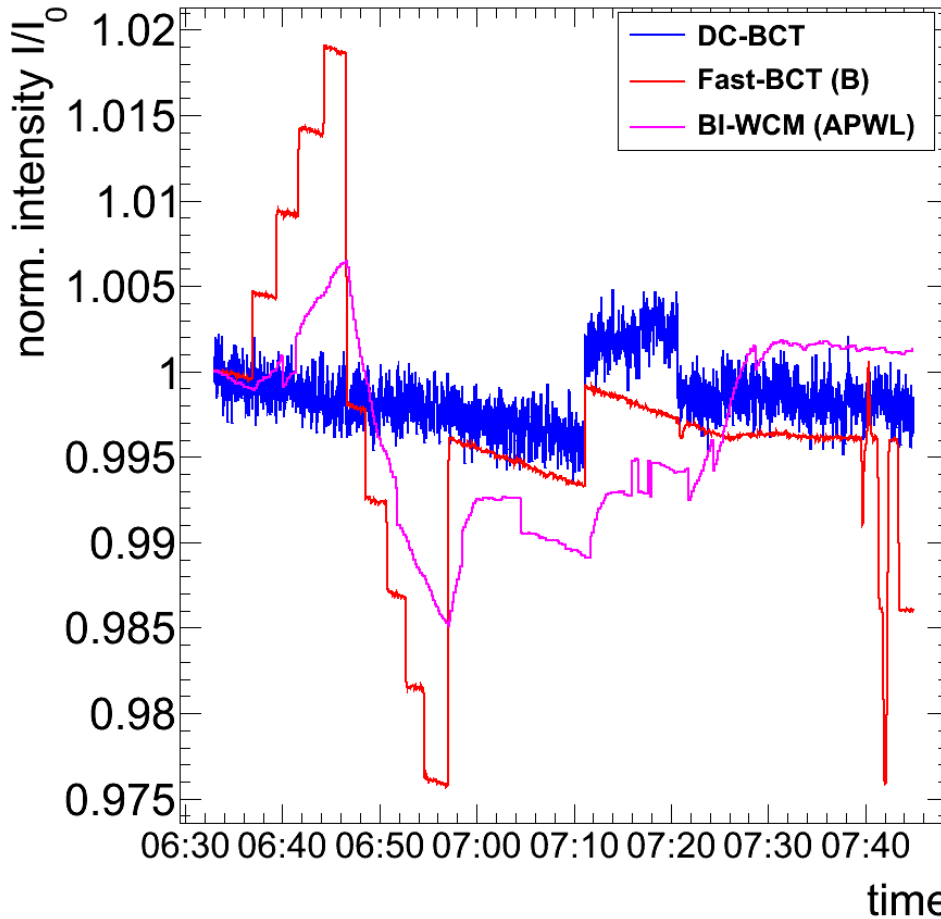

- Usually suppressed by ± 200 μm orbit stability during regular operation

- Our garden variety: Agilent 54853A (DSO 90000), [LeCroy WavePro 7300 A \(7Zi\)](#), Tektronik & under evaluation: GUZIK's GSA digitizers

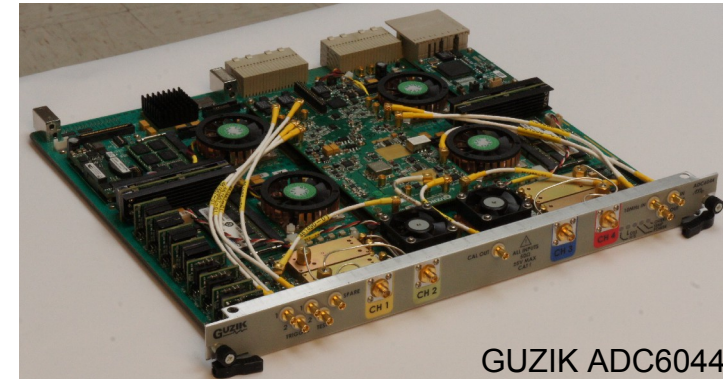
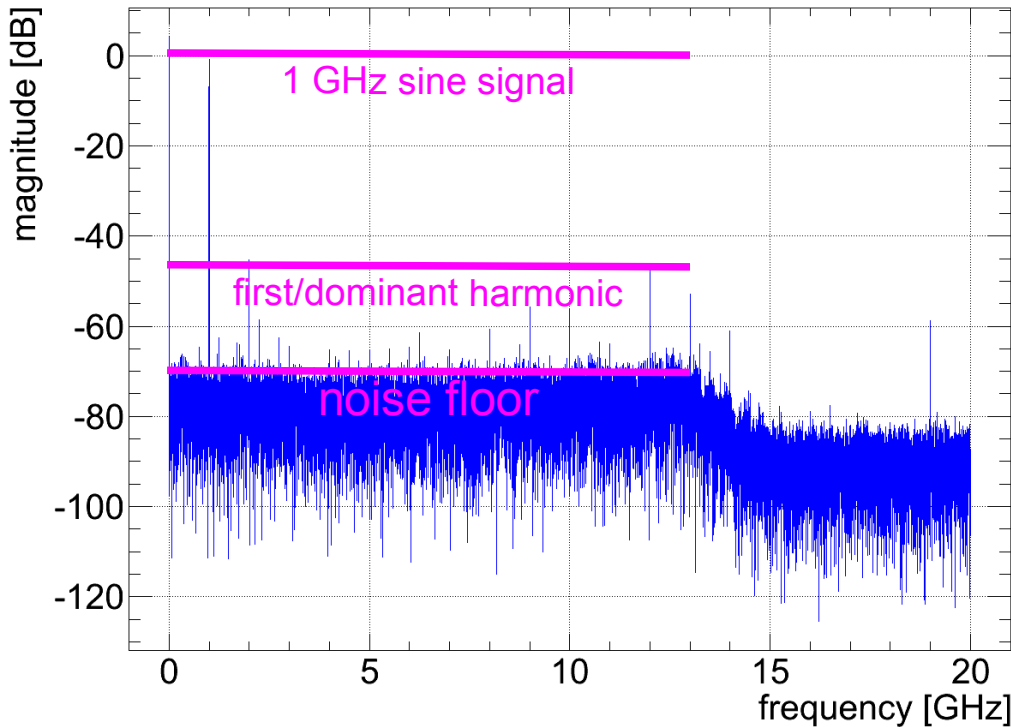

GUZIK ADC6044

- Analog performance very similar between systems/brands:
 - Signal-to-Noise-And-Distortion (SINAD) ratios of typically ~44 dB
 - ~1% accuracy on absolute intensity measurements
 - Noise-floor sufficiently flat/white up to the specified bandwidth
 - can gain in resolution resolution for repetitive signals

Turn-by-turn acquisition using

A) **Instantaneous 'raw' data**: intensity resolution Δn_b limited by 8-bit quantisation, ADC noise (ENOB) and number of samples per bunch n_s

$$\sigma(n_b) \sim \frac{1}{\sqrt{n_s \cdot 2^{ENOB}}}$$

– LHC ($4\sigma_t \sim 1$ ns, 10 GS): $\sim 10^{-3}$ PS ($4\sigma_t \sim 5$ -10 ns, 10 GS): $\sim 10^{-4}$

B) **Average over n_{turn}** : $\sigma(\bar{n}_b) \sim \frac{1}{\sqrt{n_s \cdot 2^{ENOB}}} \cdot \frac{1}{\sqrt{n_{turn}}}$

– LHC: $<10^{-4}$ (10^{-6})@0.1Hz & PS: $<2 \cdot 10^{-4}$ ($2 \cdot 10^{-5}$)@0.1Hz achieved (theo.)

– n_{turn} essentially only limited by

- required measurement bandwidth/time-scale the parameter changes
- acquisition HW limitations, e.g. LHC: tested oscilloscopes average in SW: 0.1 Hz bandwidth \leftrightarrow 112k turns max needed to be limit the to 500 turns/10s (data transfer limit) \rightarrow upgrade in place/being evaluated

C) **Dynamic range splitting**: resolution is basically the same as raw turn-by-turn acquisitions but shifting range for satellite/ghosts into favourable ADC range

– First results are quite promising... see later slides

- From a pure resolution point of view: "Can detect Ghosts by Eye"

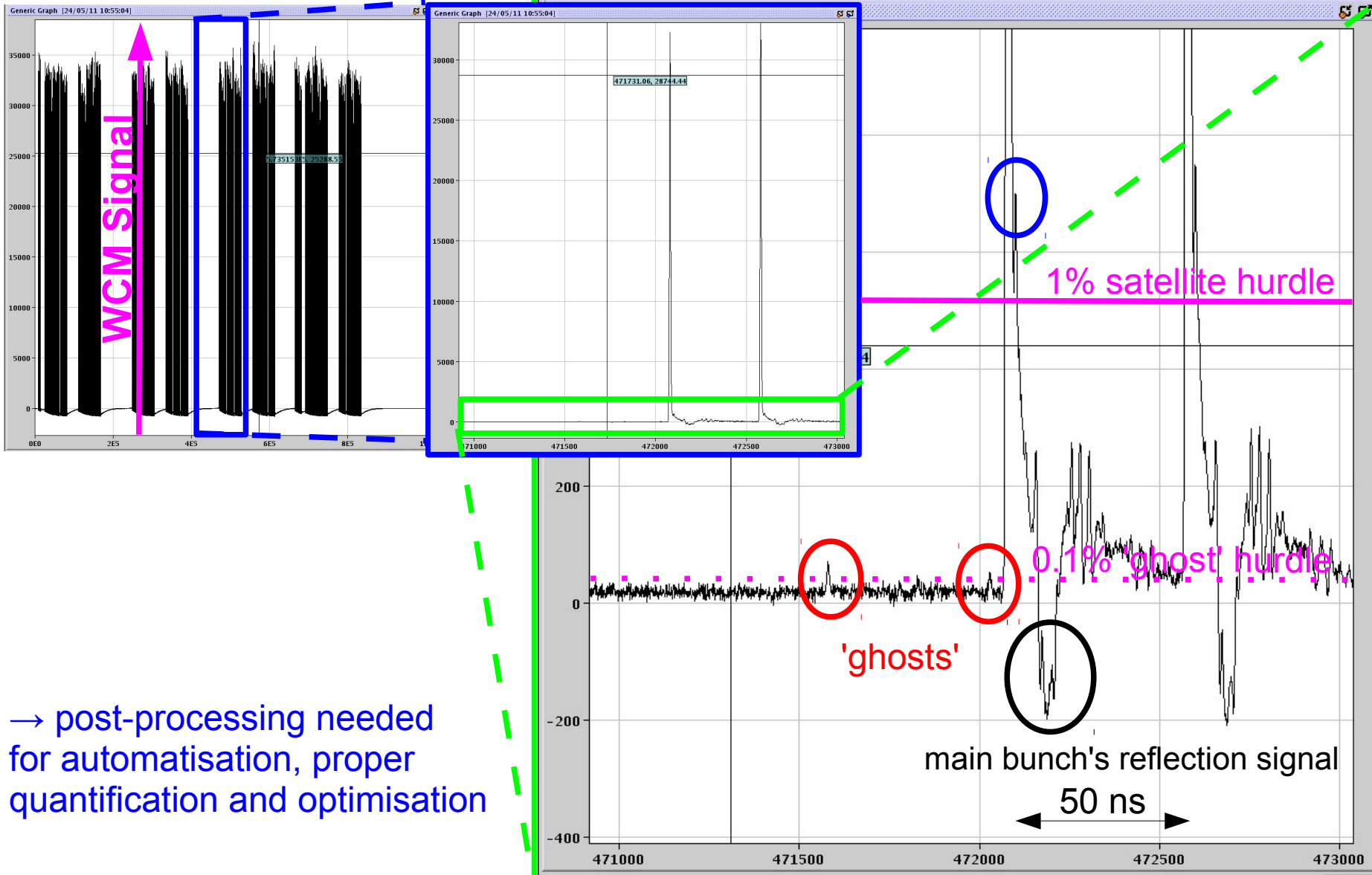

→ post-processing needed for automatisisation, proper quantification and optimisation

- Detection needs to be done in the presence sub-% level reflection caused by unavoidable installation imperfections and variable systematic background caused by temperature effects of dielectrics and ferrites in cable/pick-up:

N.B. $Z_0 \sim \sqrt{\frac{\mu_r}{\epsilon_r}}$

$$\frac{\partial}{\partial T} \left(\frac{\Delta \epsilon}{\epsilon} \right) \sim \pm 30 \text{ ppm}/^\circ\text{C} \quad (\text{e.g. ceramics})$$

$$\frac{\partial}{\partial T} \left(\frac{\Delta \mu}{\mu} \right) \sim 0.1 \dots 1 \cdot 10^{-2} / ^\circ\text{C} \quad (\text{typ. ferrites})$$

- Going below 10^{-3} -level requires additional measures. The most promising combination found:
 - I. Sub-percent level compensation of the pick-up response
 - Classical Fourier-/Wiener-filter based Deconvolution
 - II. High-frequency Noise Rejection
 - Savitzky-Golay χ^2 -fitting¹
 - III. Base-line restoration
 - SNIP background estimate^{2,3}

¹A. Savitzky and M. Golay, "Smoothing and Differentiation of Data by Simplified Least Squares Procedures", Analytical Chemistry, Vol. 36, No. 8, July 1964, pp. 1627–1639

²C.G. RYAN et al., "SNIP, A Statistics-Sensitive Background Treatment for the quantitative Analysis of PIXE Spectra in Geoscience Applications, NIM B34 (1988), 396-402

³M. Morháč, J. Kliman, V. Matoušek, M. Veselský, I. Turzo: "Background elimination methods for multidimensional gamma-ray spectra". NIM, A401 (1997) 113-132.

I. Linear Response Compensation I/II

- Real-life installation will deviate from what has been measured in the lab before installation → requires re-calibration with beam, principle:

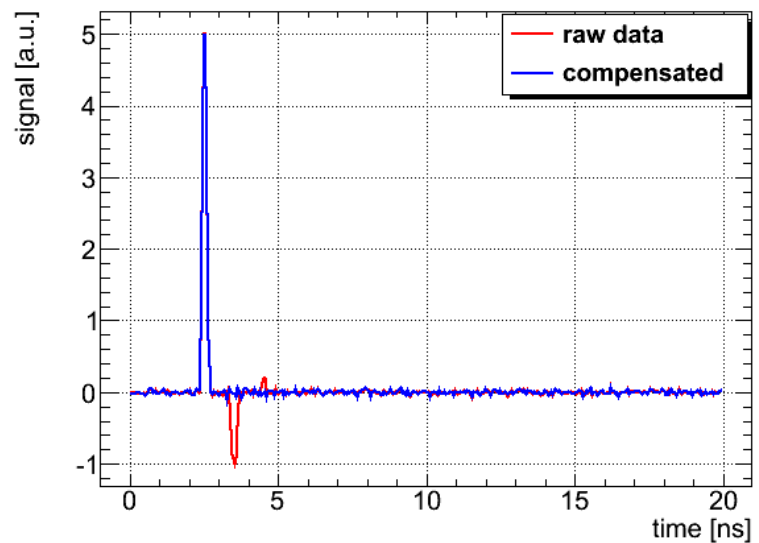
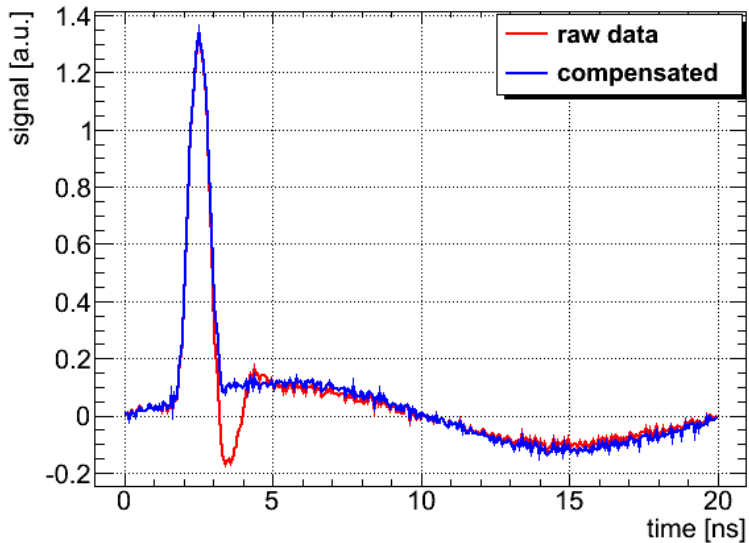
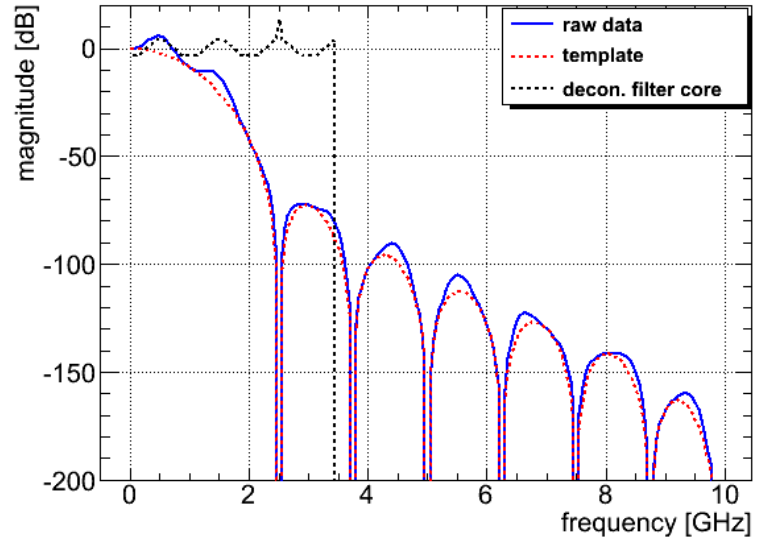
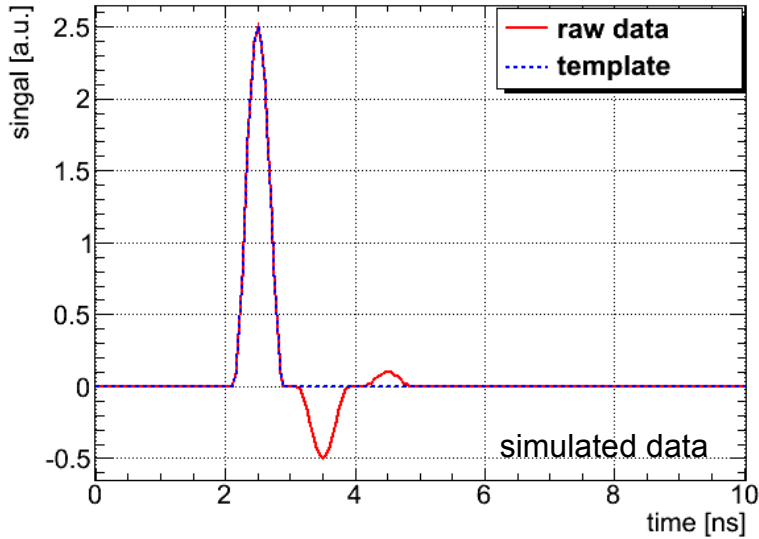

I. Linear Response Compensation II/II

– Life-Beam Data

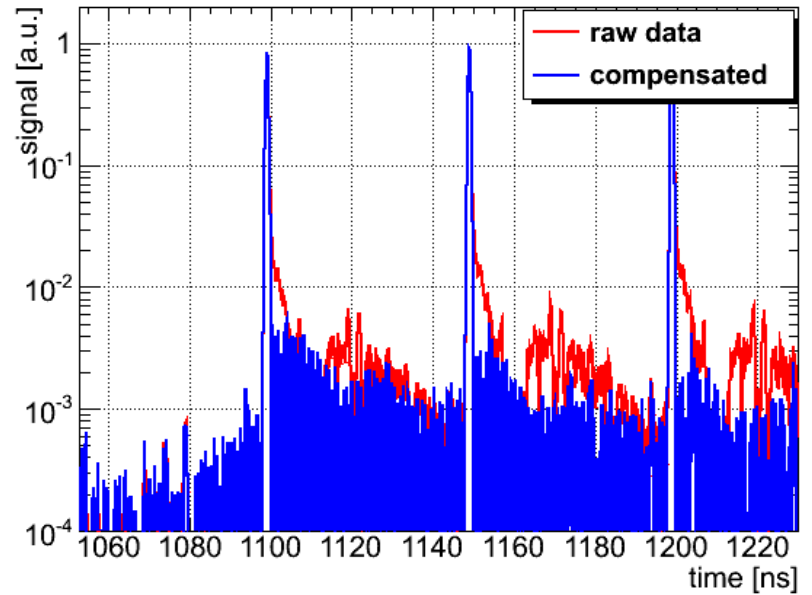
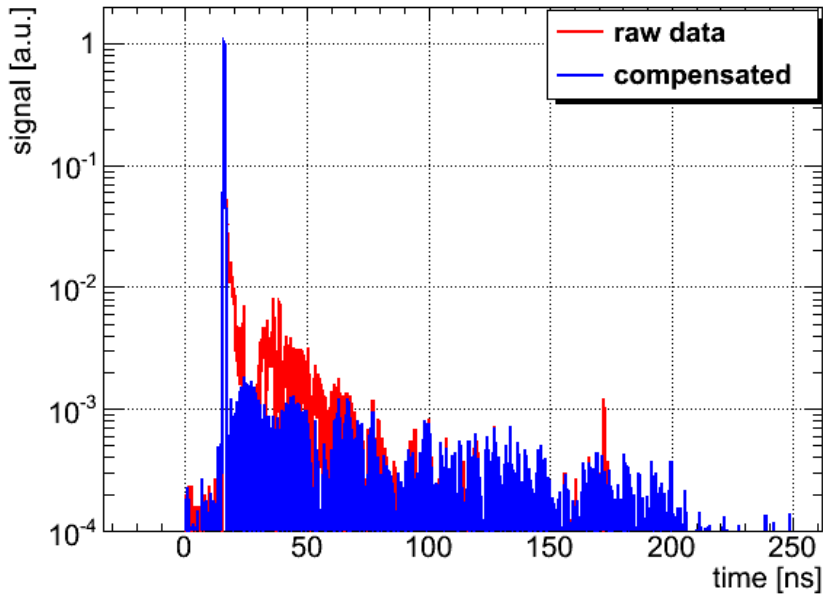
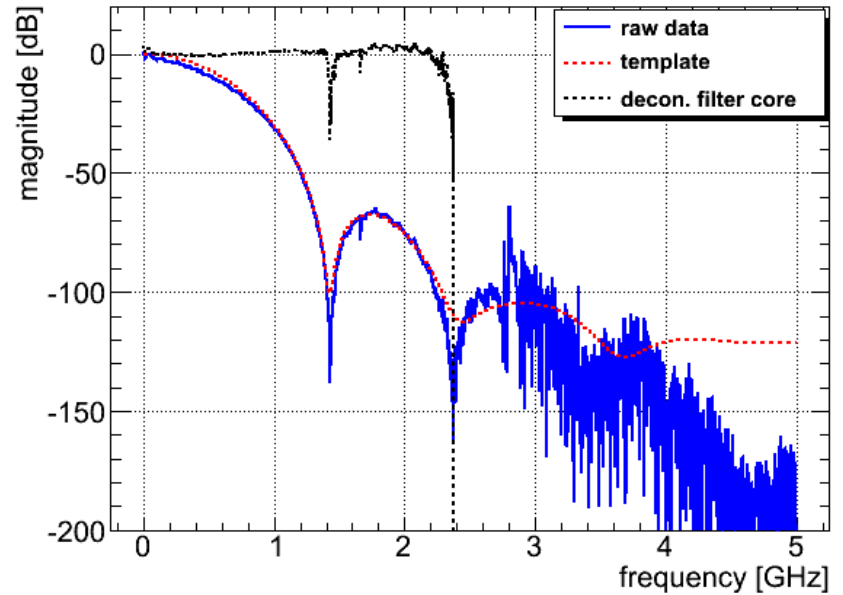
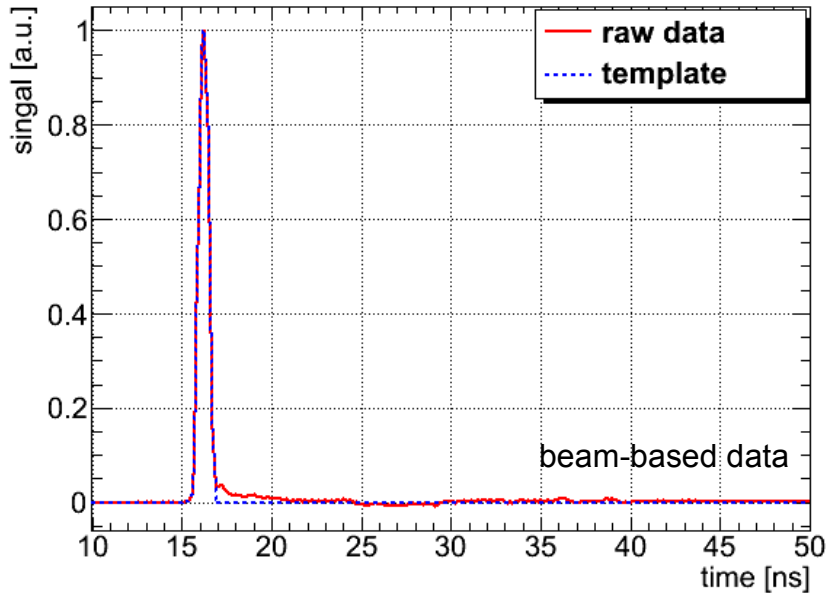

II. High-Frequency Noise Rejection – Average vs. X^2 -Fit based Method (Simulation)

- Sliding-Average or low-pass filter may distort signal amplitude and shape

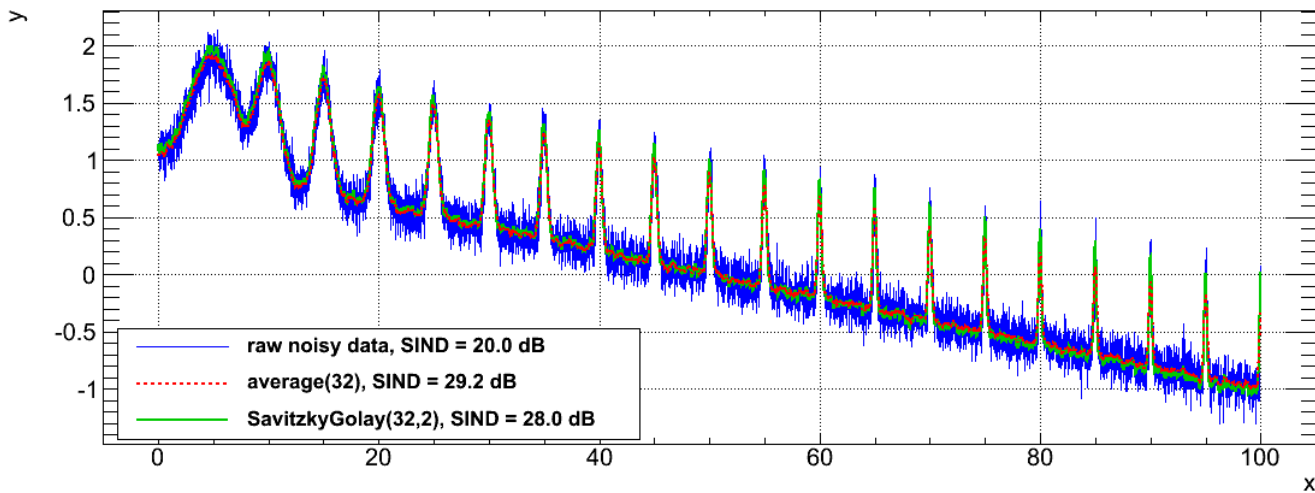
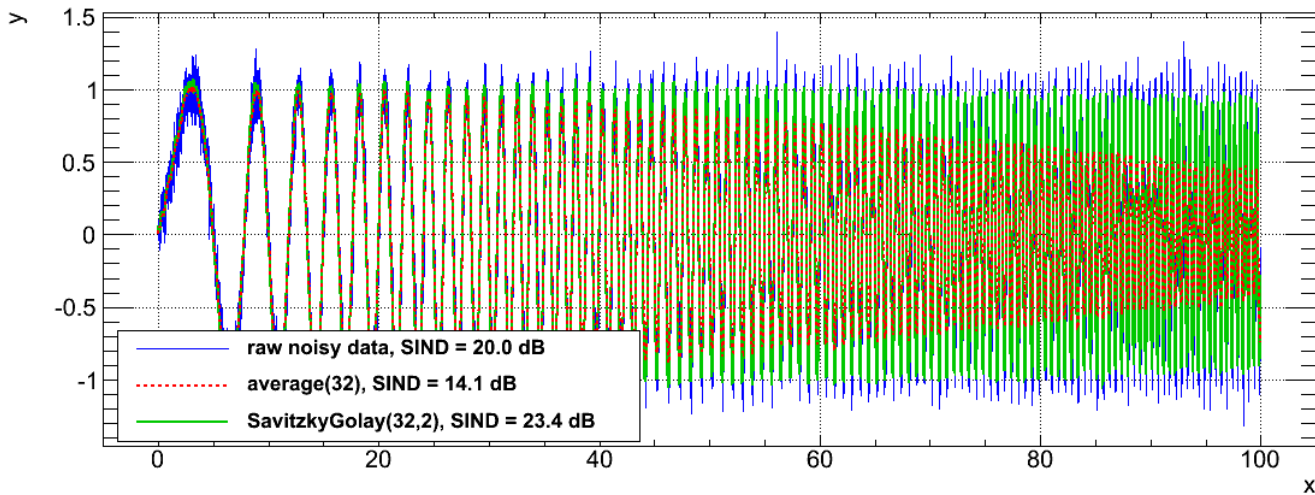

- Depending on bunch-shape/width, x^2 based-method has ~20dB higher SIND

II. High-Frequency Noise Rejection – Example SPS

- Example: single bunch in the SPS at flat-top before extraction (black trace: reference based on 100 turn average)

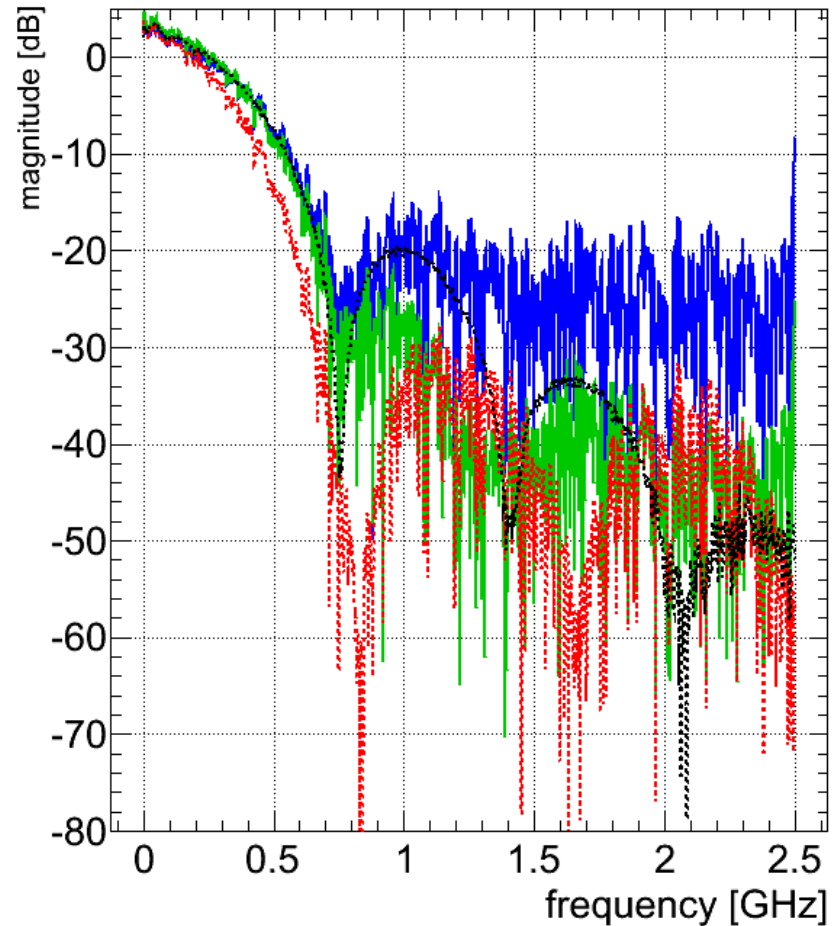
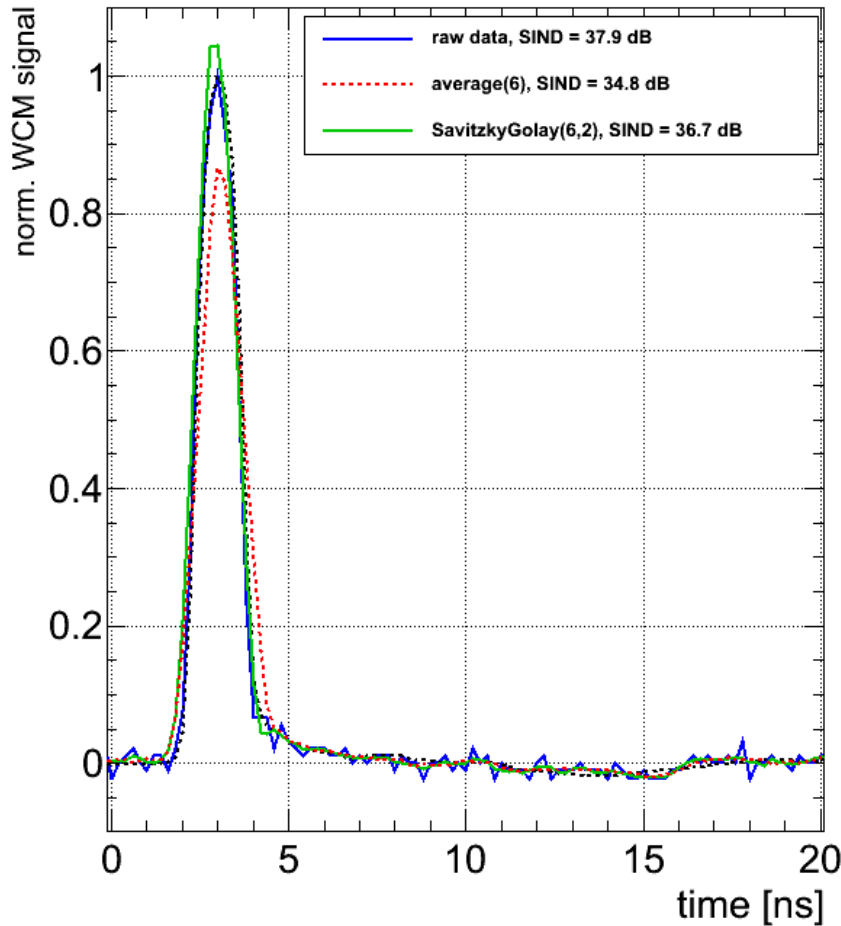

- Savitsky-Golay algorithm is de-facto a dynamic low-pass filter (within limits)

III. Base-Line Restoration – SNIP Algorithm

Example PS WCM Signal

- Satellites have been deliberately produced for better proof-of-principle:

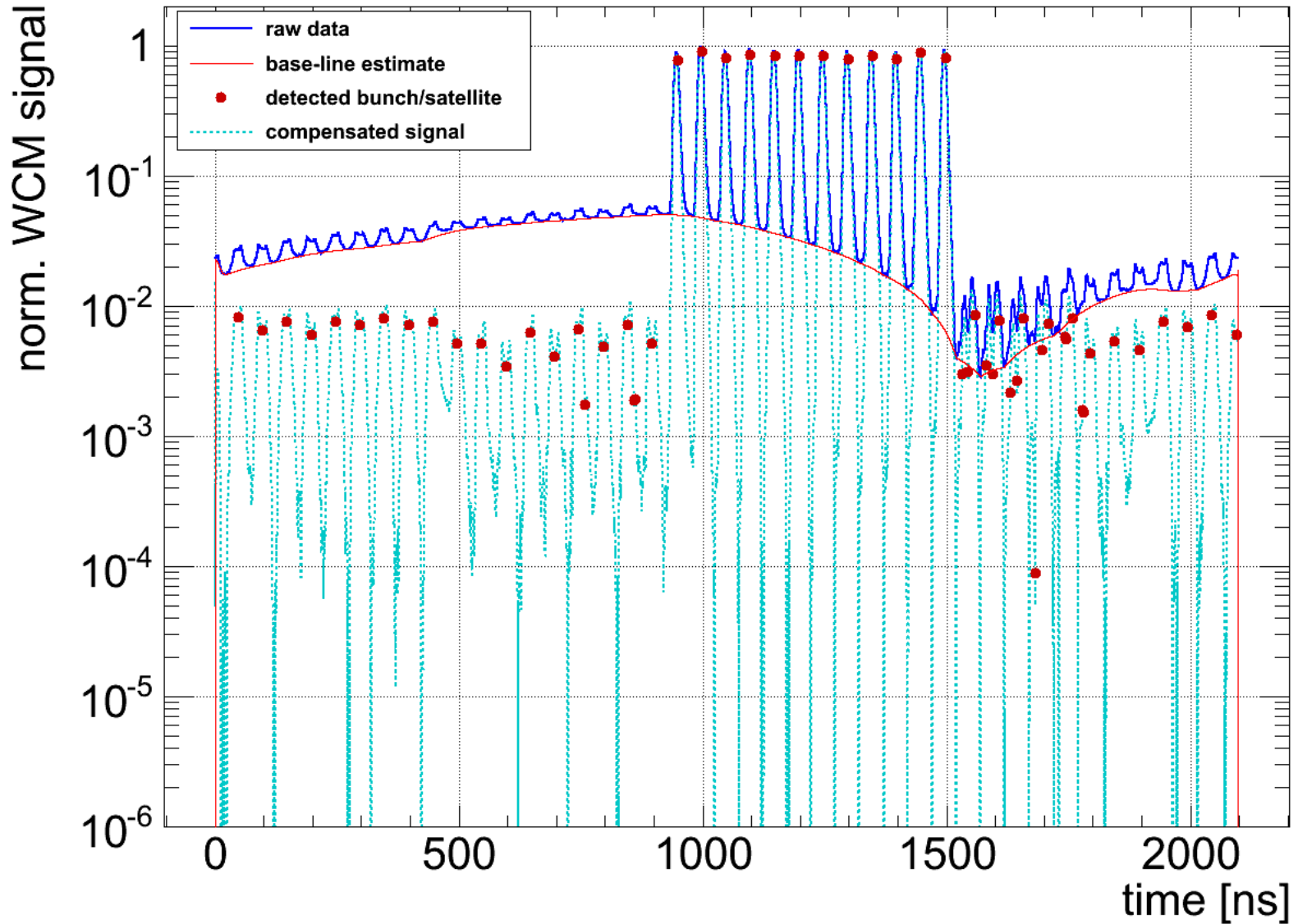

III. Base-Line Restoration – SNIP Algorithm

Example PS WCM Signal - ZOOM

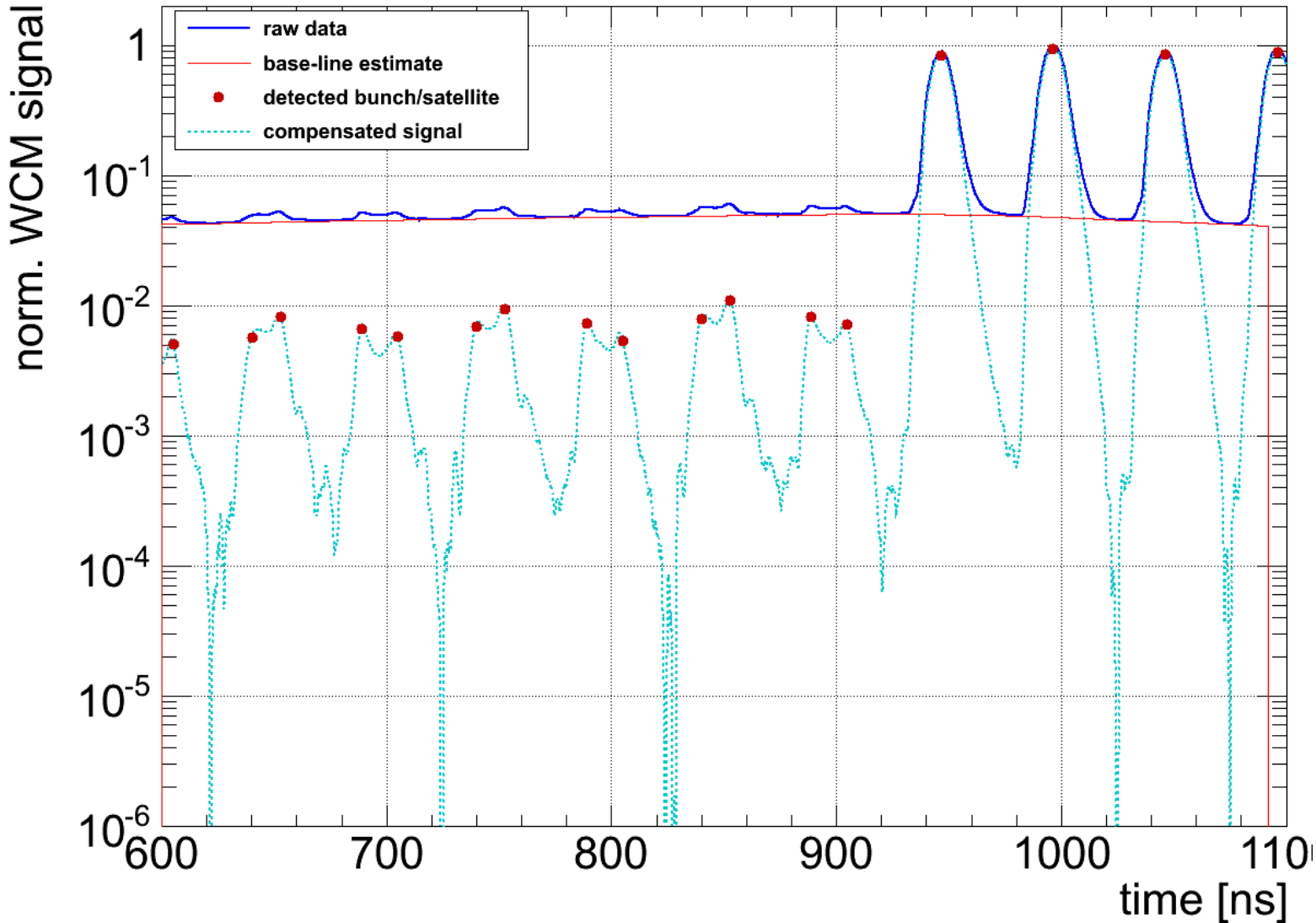

- Especially satellites/ghosts may have very special distributions (e.g. hollow for recaptures particles → double peak structure)

- Idea: split signals and saturate one copy to zoom-in on satellites
 - possible due fast-recovery time of oscilloscope's input pre-amplifier and/or dedicated diode clamping circuit
 - saturated channel can be normalised w.r.t. full range copy
 - limit: droop that has to be accomodated by the ADC range
 - advantage: get reasonable results sub-% estimates within few turns!!
 - Some caveats/design constraints:
 - Some digitizers inputs are not protected → ded. clamping circuit is mandatory!
 - Clamping creates reflection that may return to the WCM/other channel
 - Matching at high frequencies (C parallel to scope input)
 - Schottky diodes need to handle the clamped power (<5 V)
 - Signal path-lengths need to be kept to a minimum

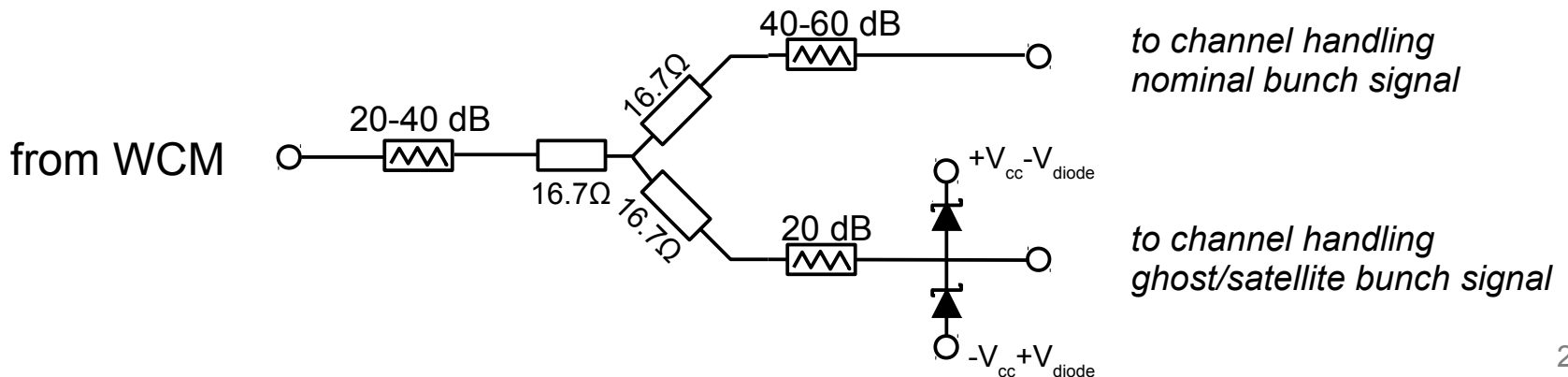

- Forcing satellites and saturating the scope input (fast recovery time)

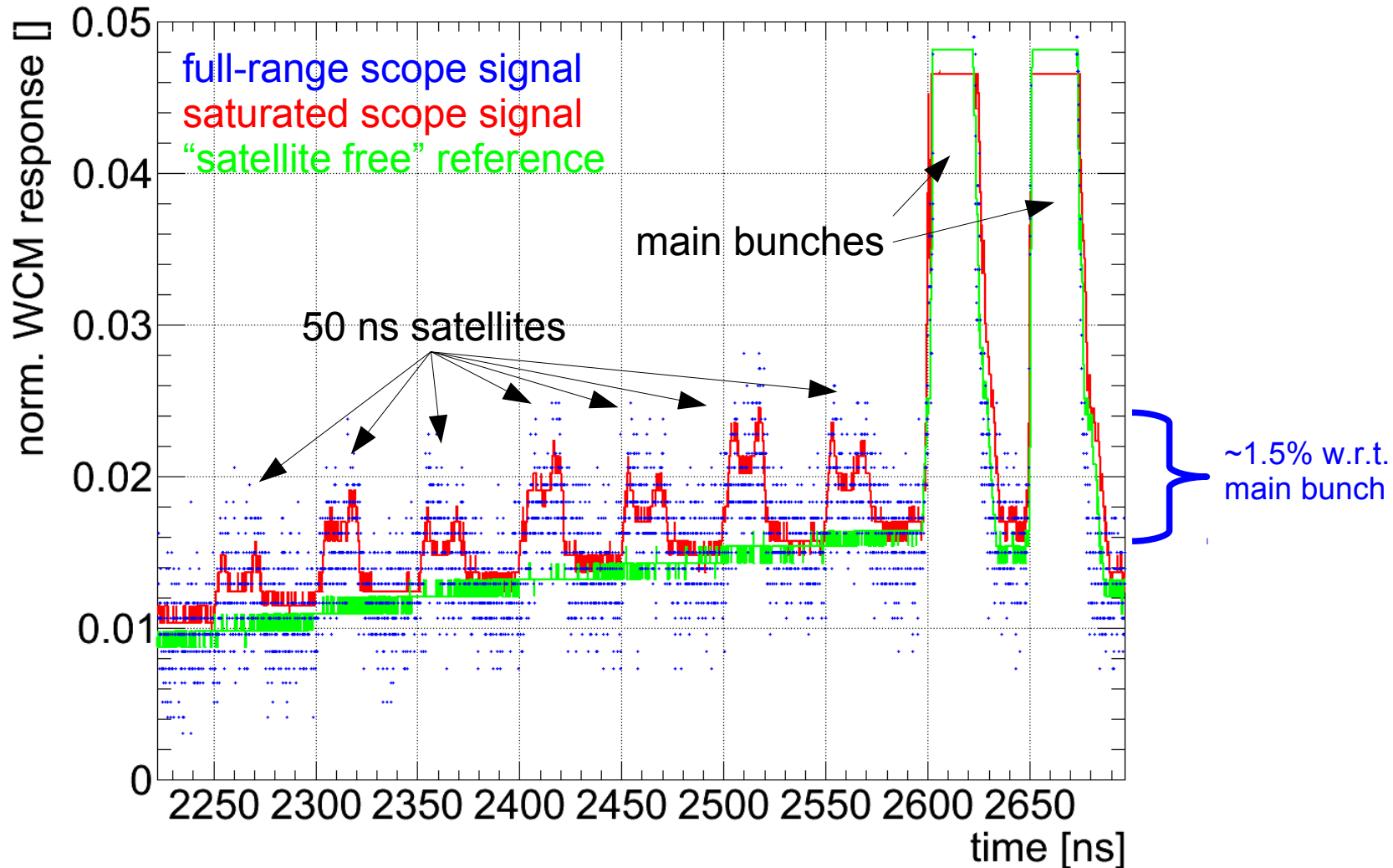

- Satellites 'visible' and results look promising but requires post treatment to compensate for reflections, pick-ups response, droop etc.

- After full post-processing chain of smoothing and removing background:

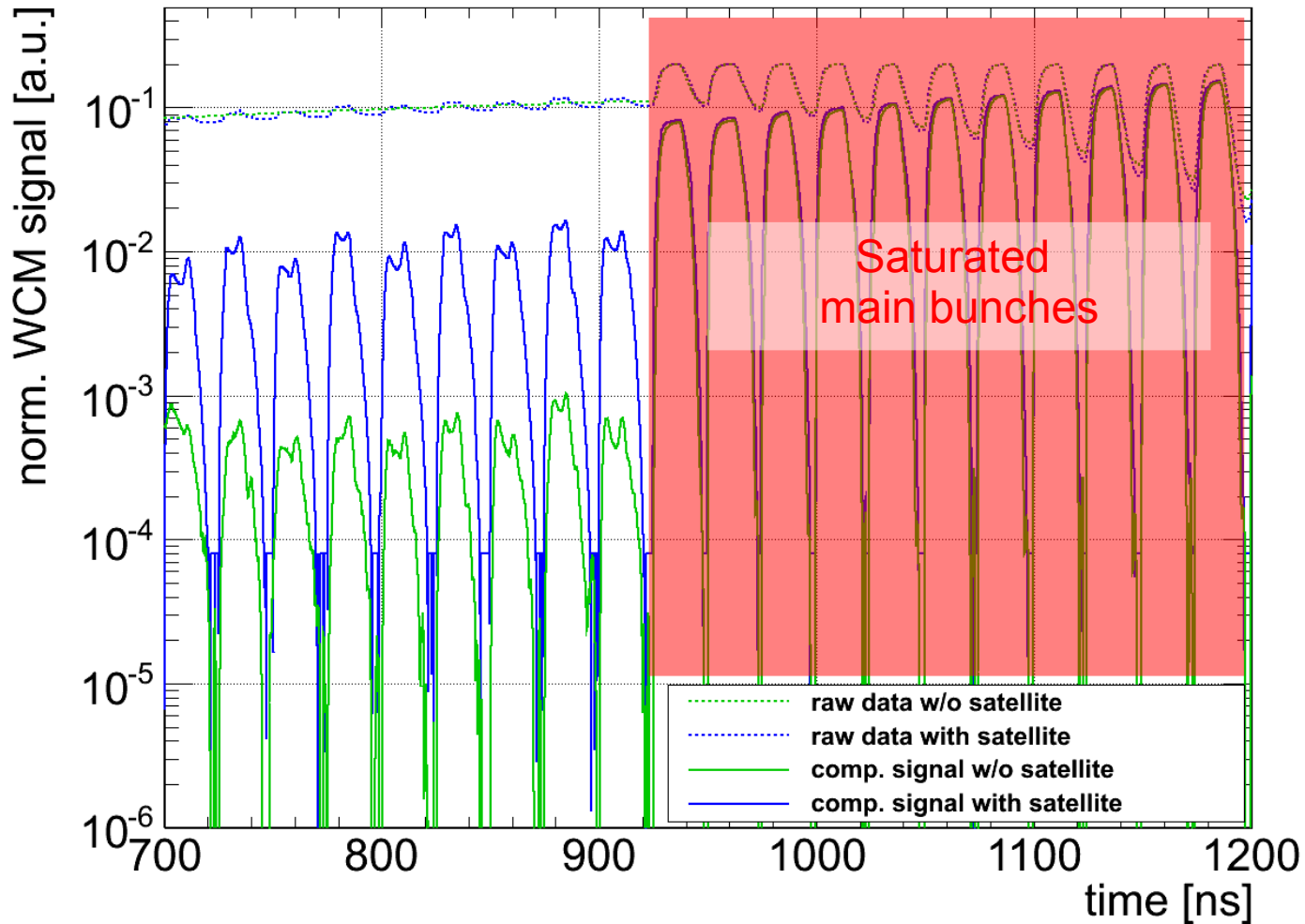

- Satellites visible in “clean” condition, prel. noise-floor estimate $\sim 10^{-5}$ w.r.t max

- Real bunches do not necessarily obey 'Gaussian' shapes

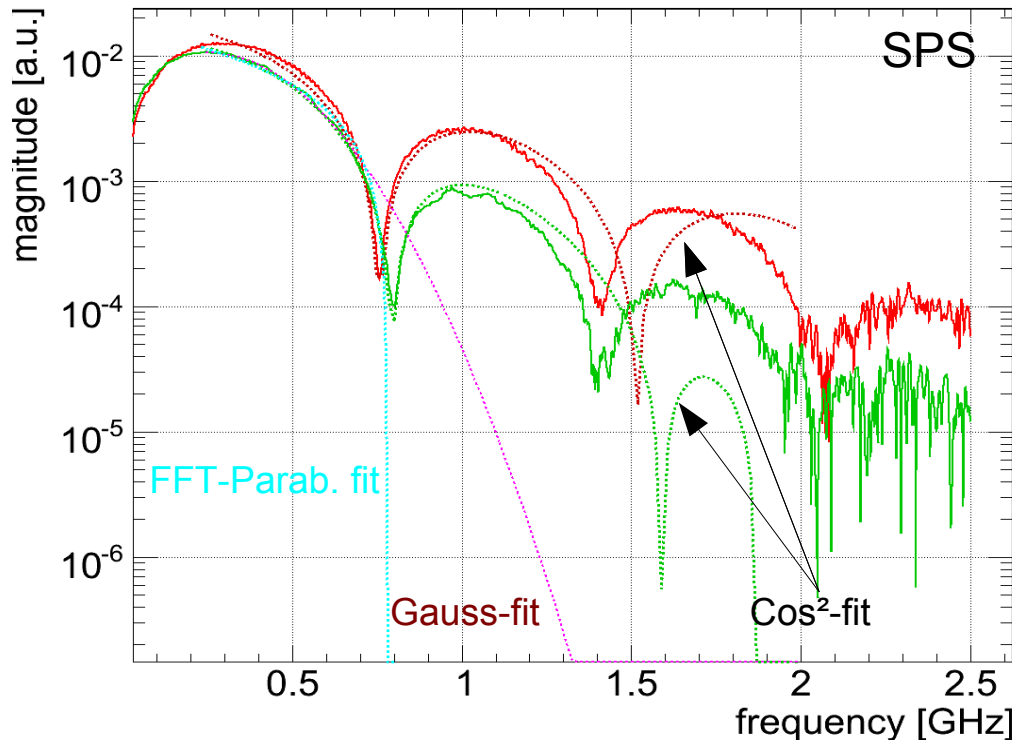

LHC Logging:

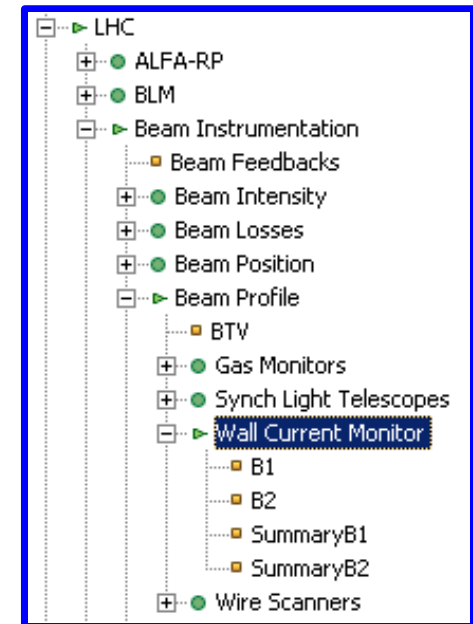

- What's derived from the WCM data up to now:
 - number & intensities of bunches & satellites (per 400 MHz bucket)
 - true Cos²- , Parabolic- & Gaussian bunch length χ^2 -fits
 - Frequency containing 50/95/99% of bunch power/intensities, peak voltages
 - Bunch profiles, power spectra (\rightarrow machine impedances), ...
- Main aim of WCM is to provide an independent tool with different systematic to cross-checks with other more precise instruments (e.g. DC- and Fast-BCTs, Schottky)

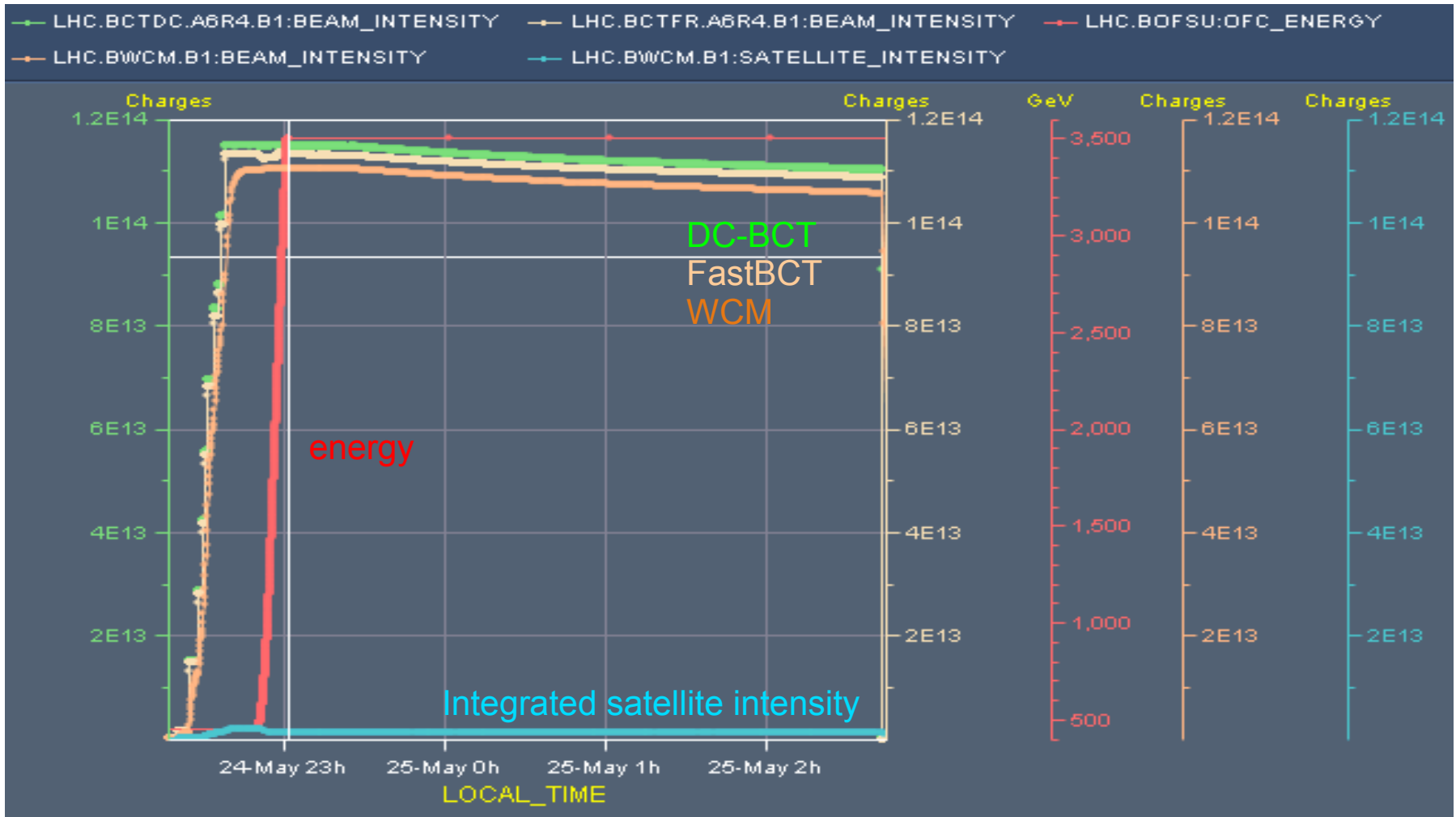

- WCM cross-calibrated to DC-BCT using a single nominal bunch (satellite free)
 - Typically percent-level beam outside nominal bucket

- Nom. empty LHC RF buckets may be filled with minute amounts of particles
→ aka. 'Satellites' and 'Ghosts' up to 10^{-6} smaller than nominal bunches
- Proof-of-principle: “Can these be detected already in the injectors before they arrive in the LHC using standard wall-current-monitors?”
- Test confirmed that the existing system...
 - can achieve 10^{-5} resolutions @3 GHz over a few turns or single-shot via:
 - a) turn-by-turn averaging over a couple of hundred turns
 - b) splitting signal and saturating its copy to specifically detect satellites
 - Requires beam-based baseline compensation since the system drifts on the up to 10^{-3} -level due to temperature, saturation and other effects
- Acquisition HW upgrade being in progress:
 - Improve to 100% duty cycle for the averaging
 - compensation algorithm and parameter done being done in FPGA

Thank you for your Attention!

Supporting Slides

Comparison of Bunch Length Estimates

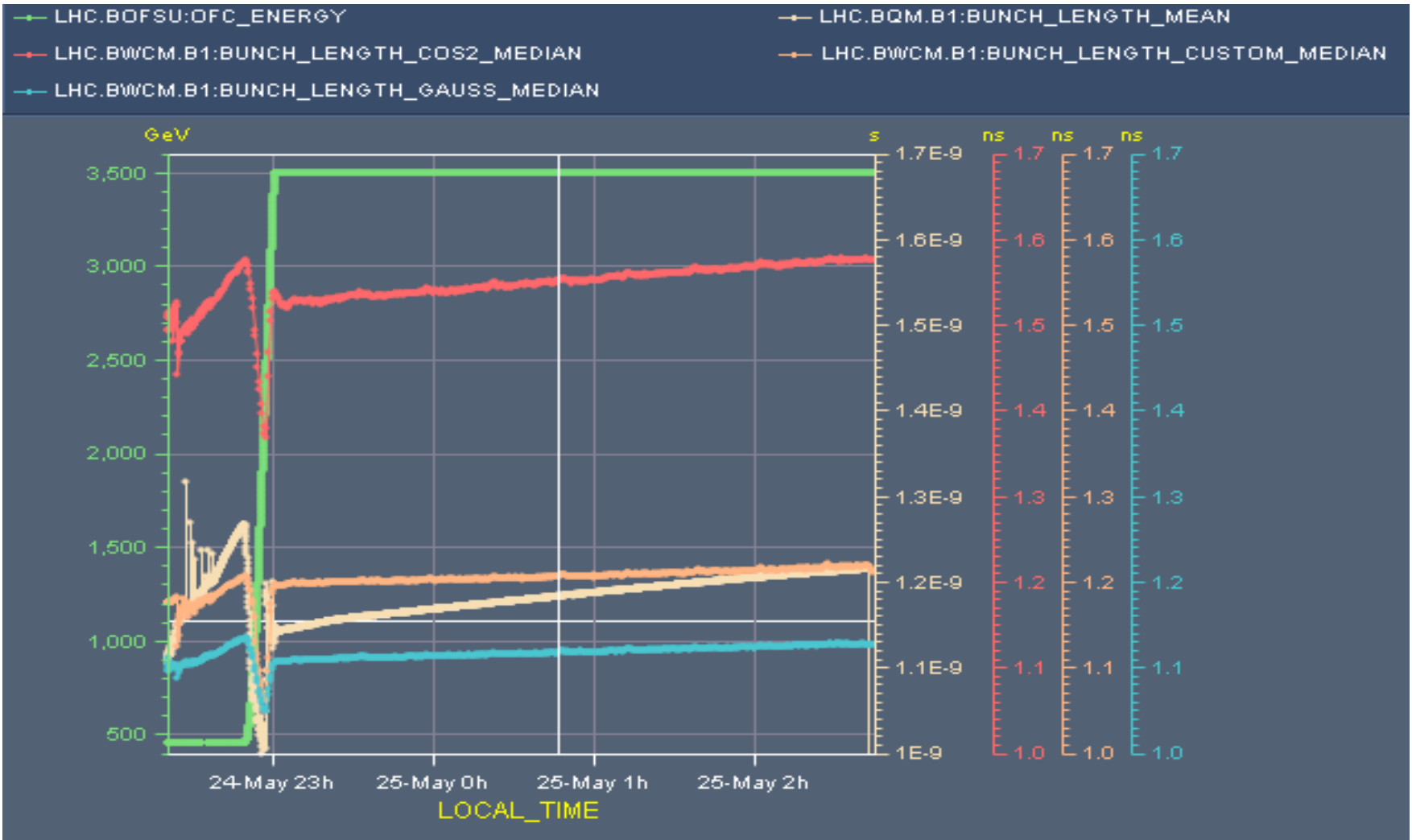

- ... there is no obvious bunch length → shape changes are important
 - difference between FWHM (BQM) and x^2 -fit Gaussian length estimate

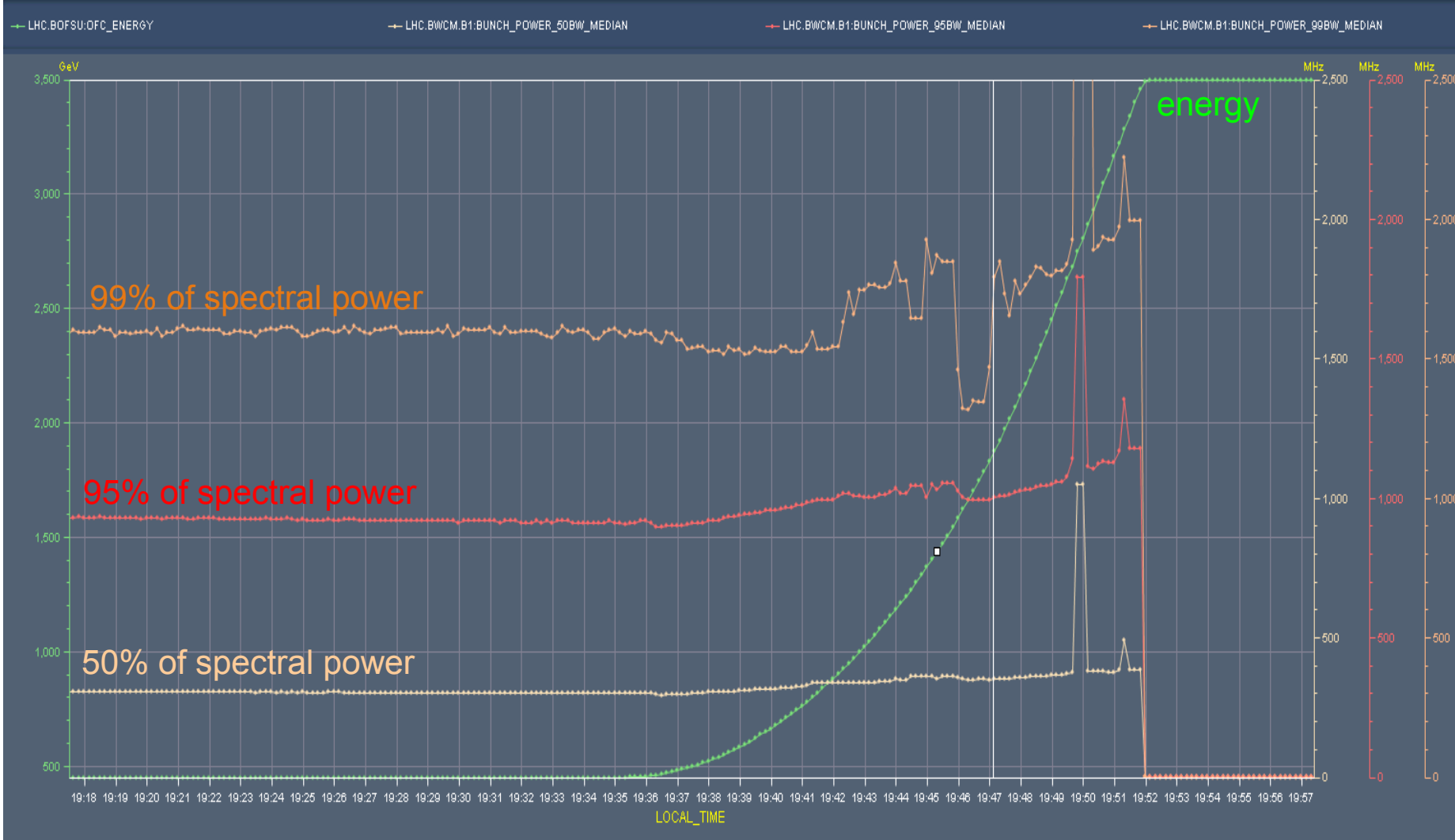

- Estimates give an indication of shape and required device bandwidths

II. High-Frequency Noise Rejection – Average vs. X^2 -Fit based Method (Simulation, Zoom)

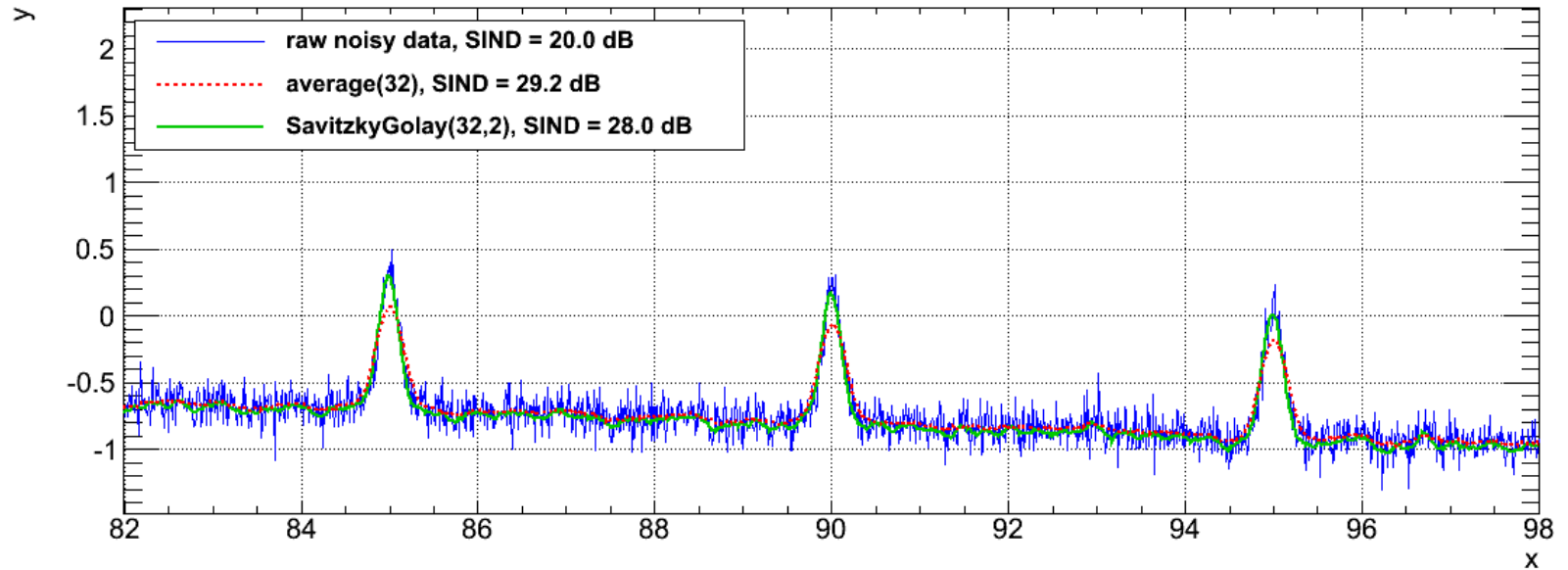
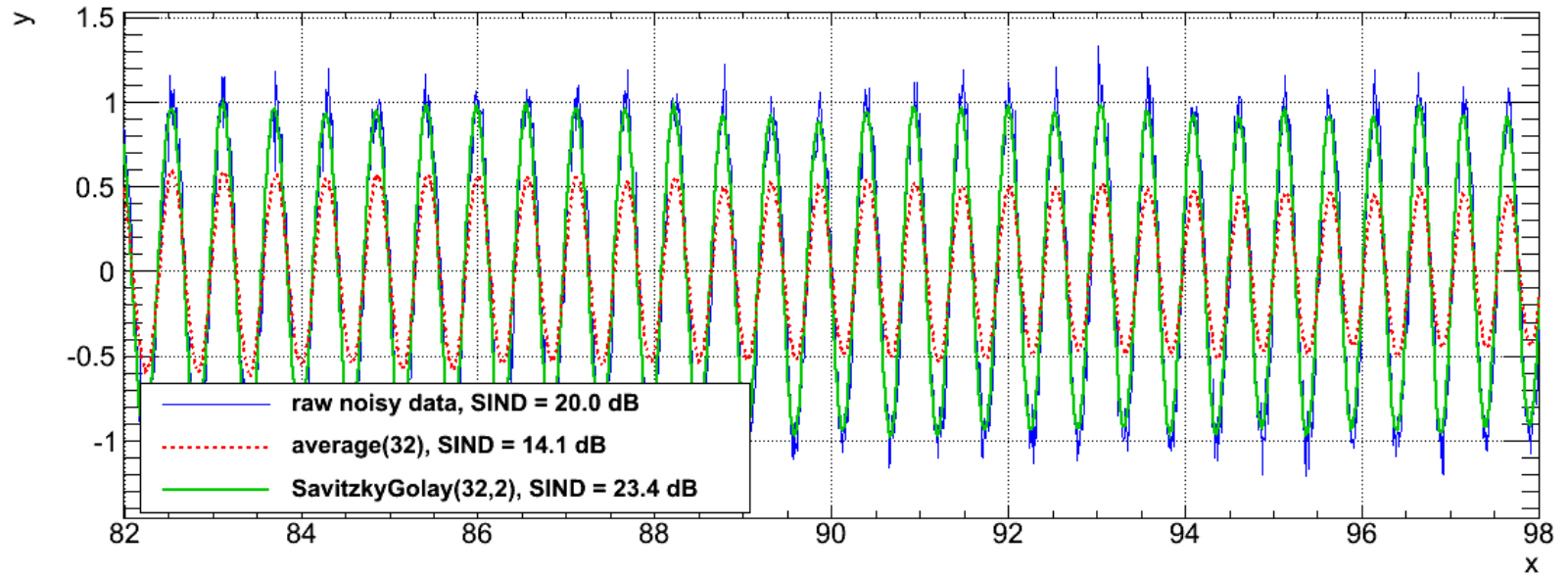

- Initial test comparing single turn acquisition

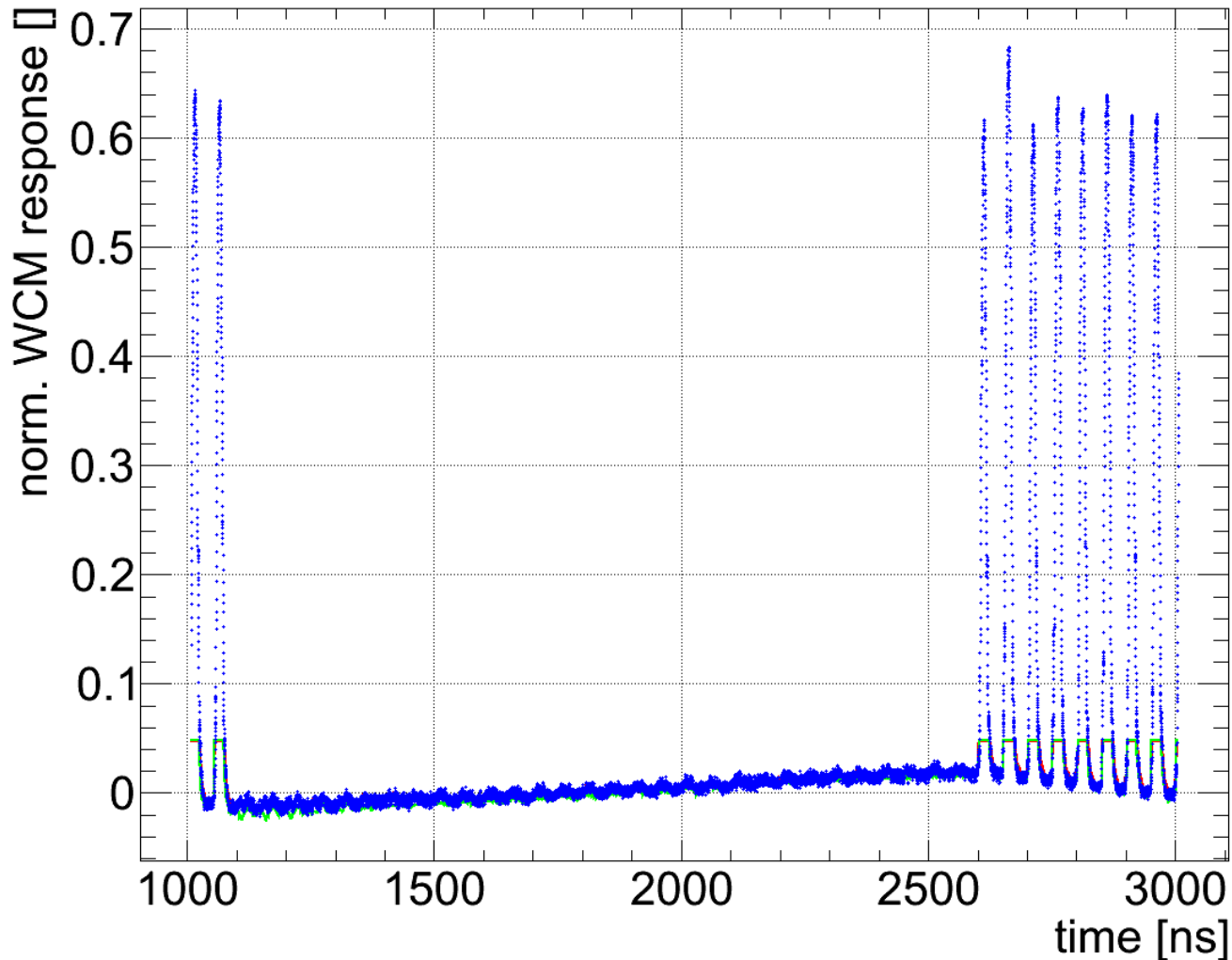

- Range limited by known systematic reflection after main bunches in 2011
→ improved for 2012

III. Base-Line Restoration – SNIP Algorithm

Example LHC WCM Signal

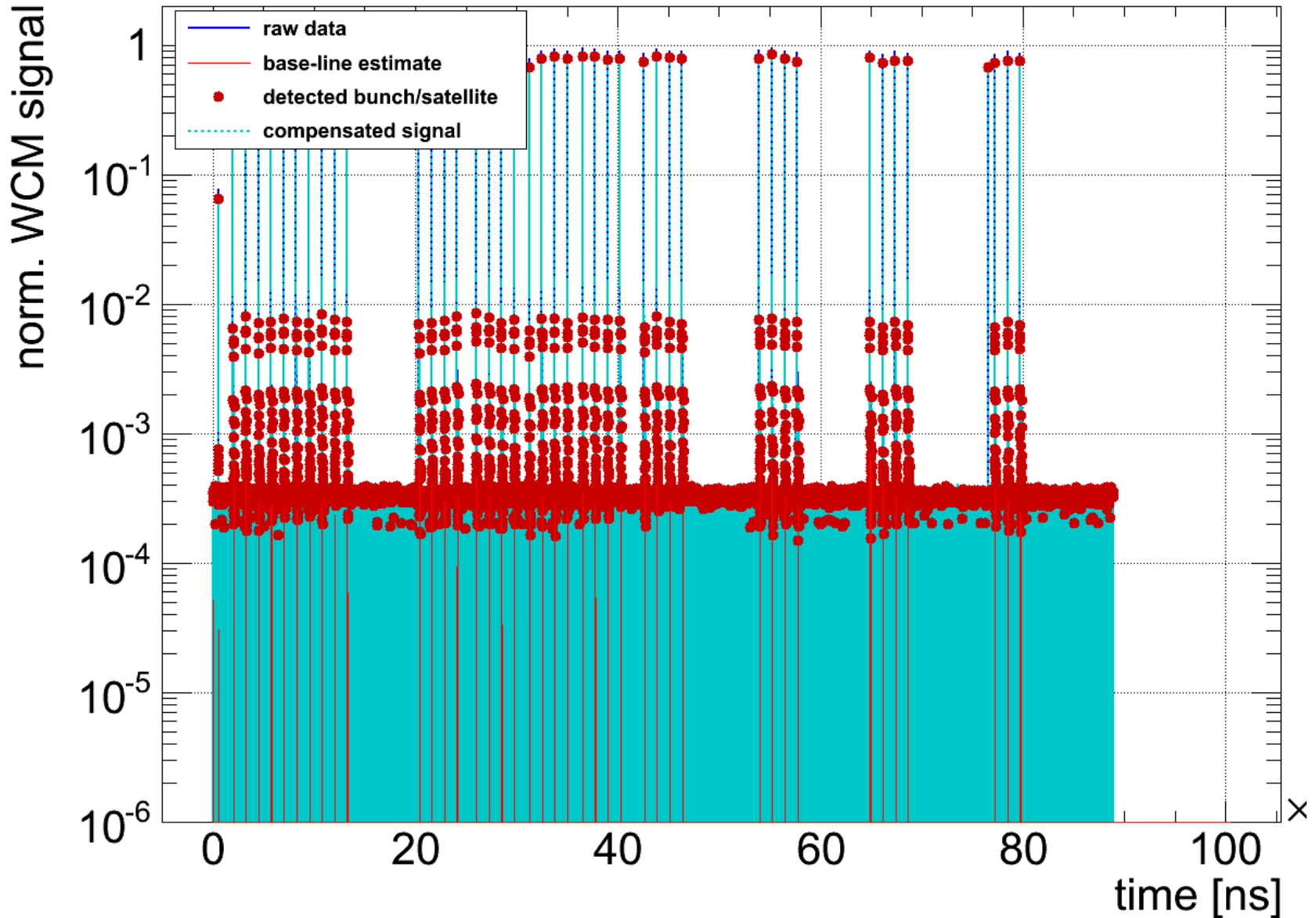

III. Base-Line Restoration – SNIP Algorithm

Example LHC WCM Signal - ZOOM

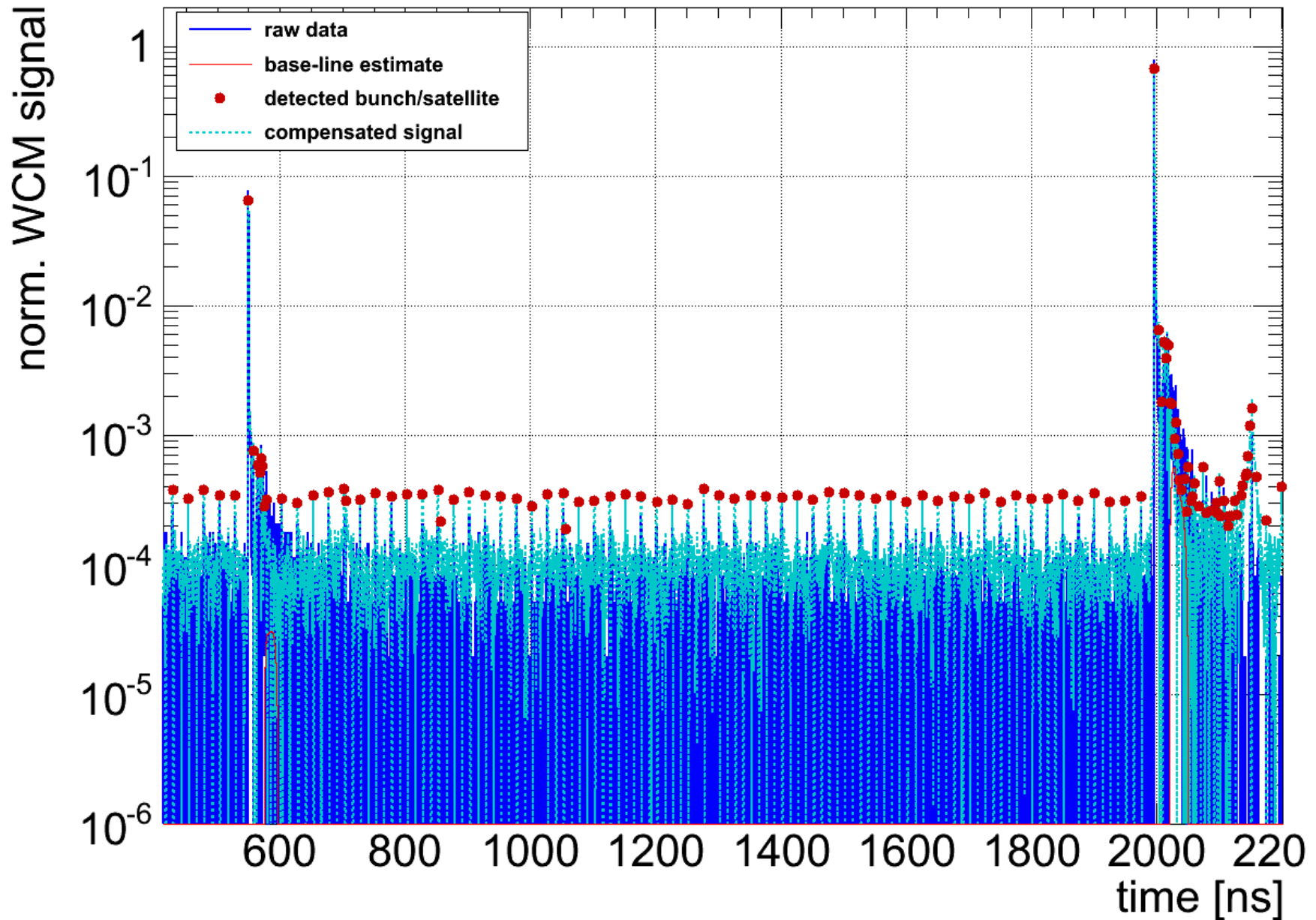

Similar Performance with Pb-Beam... S/N ratio of below the 10^{-3} level

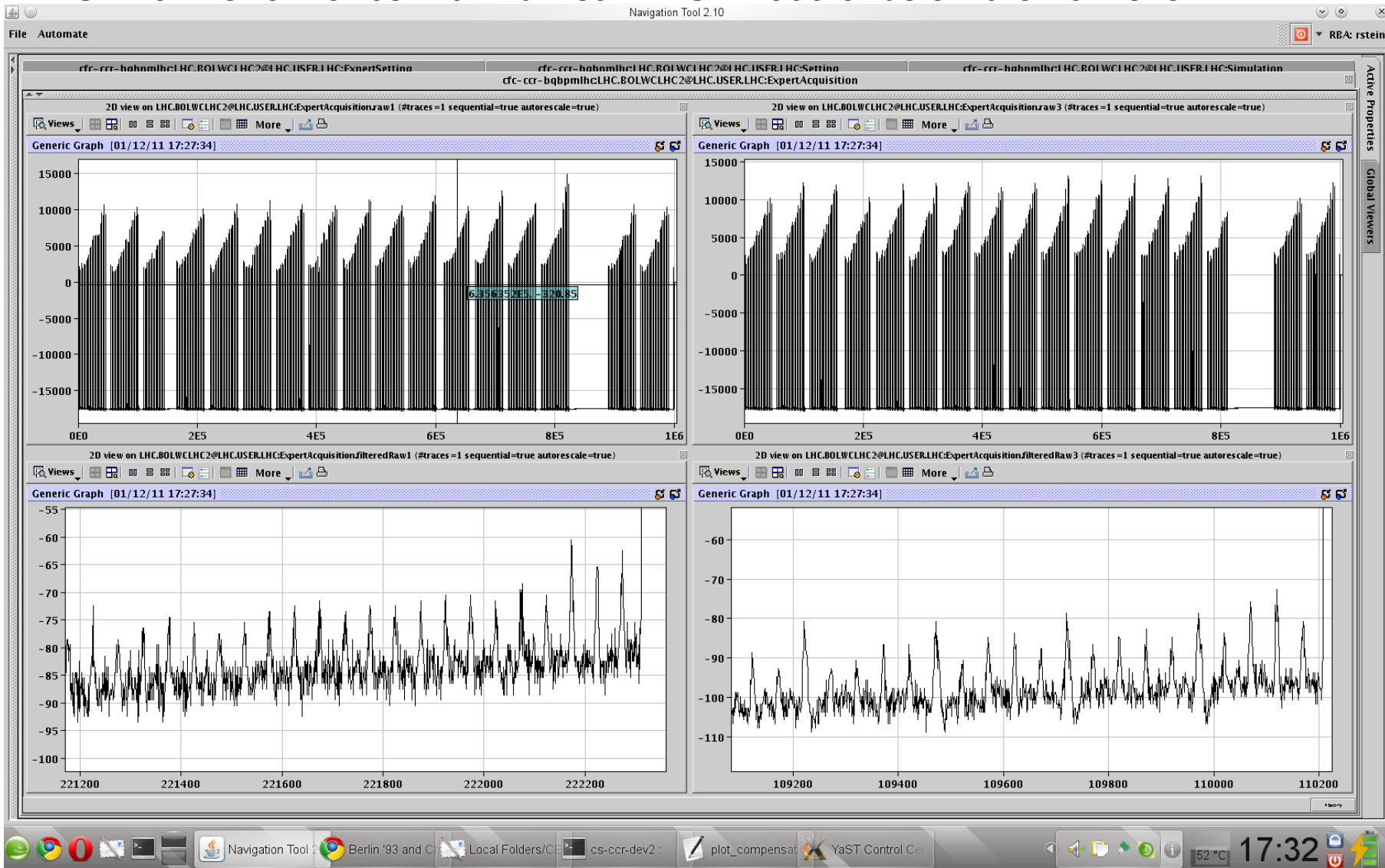

Why not using simply Fourier Spectra's DC-Component

- Fourier Integral definition for ' $\omega:=0$ ':
- DC information is in-accessible
 - AC-coupling of WCM (~50 kHz)
 - Short bunches (<1ns @25ns) ↔ spectral leakage, difficult to resolve structures < 40 MHz
 - Bunch shape-dependence if 'interpolating' to DC or applying “magic” numbers

$$F(\omega) = \int_{-\infty}^{+\infty} f(t) e^{-i\omega t} dt$$

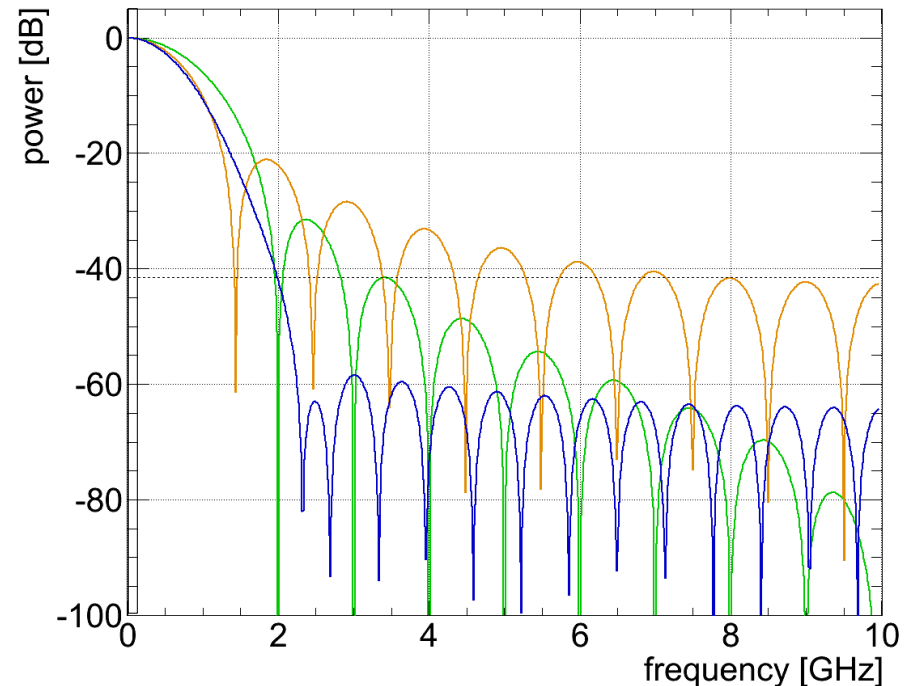
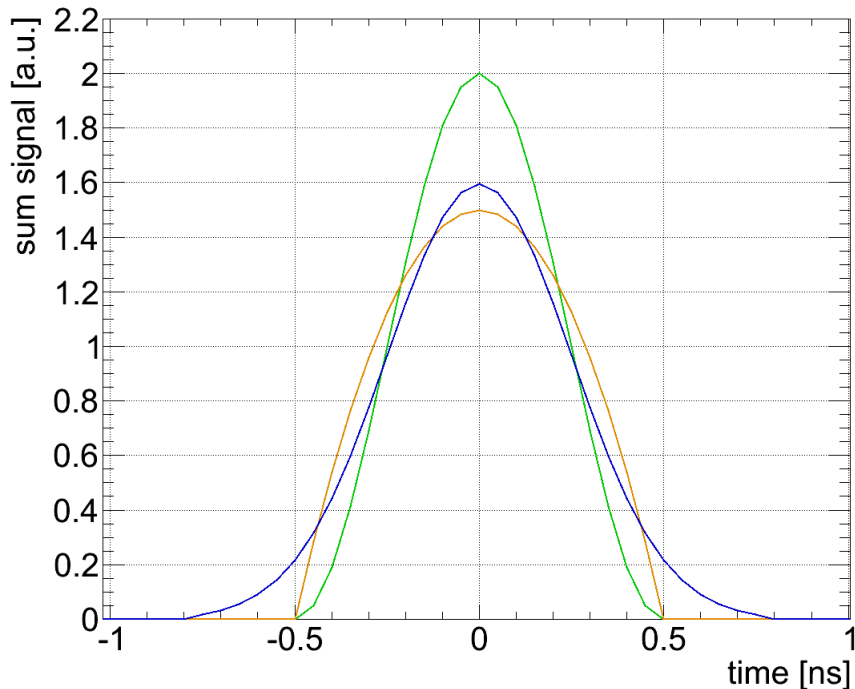

- Example: satellites 50 (PS?) and 2.5 ns (LHC) prior to bunch train

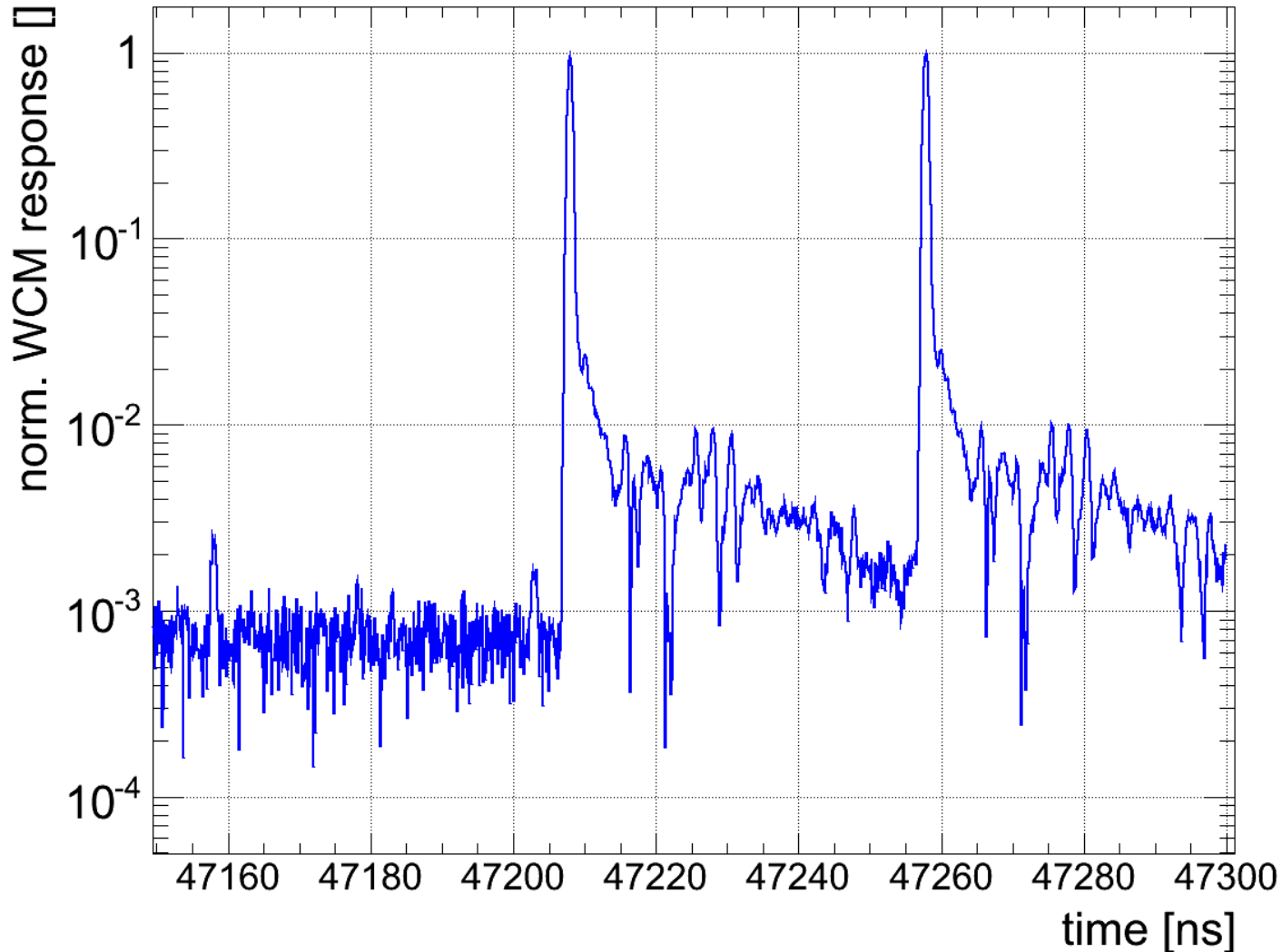

- 2.5 ns satellites after bunch visible but dominated by WCM tails/reflections...

- “Mother” design for LHC APWL, would expect similar performance

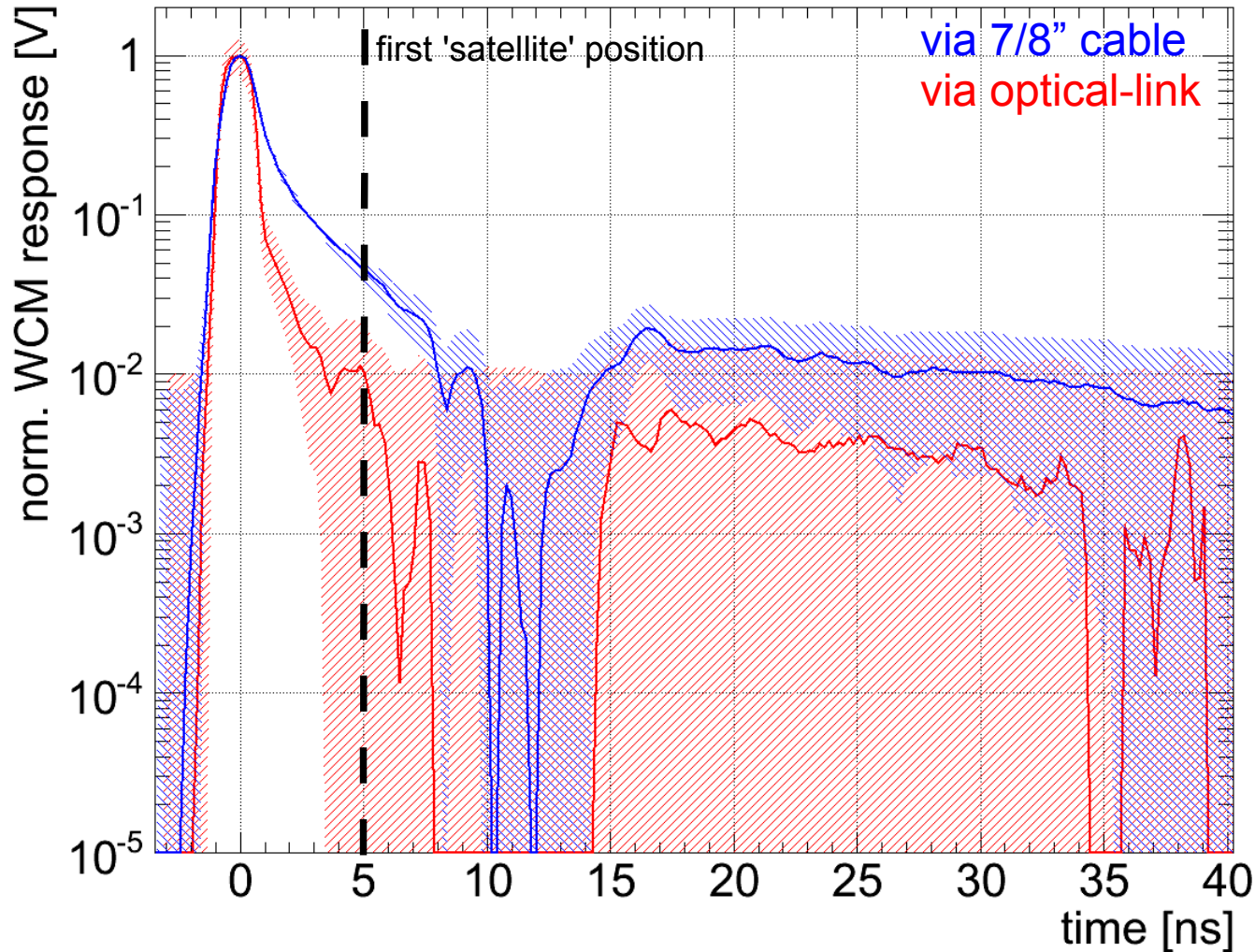

- higher bandwidth with optical link but noise compared to 7/8" cable
 → shorter cables/acquisition system in the SPS tunnel needed